



# Service Manual

## Serial Number Range

**GR-12**

from GR10-20000  
to GR16-40865

**GR-15**

from GR16P-40866  
to GR16P-44699

**GR-20**

from GRP-44700  
from GRR-101

**QS-12R**

from QS11-1000  
to QS16-2429

**QS-15R**

from QS16P-2430  
to QS16P-4499

**QS-20R**

from QSP-4500

**QS-12W**

**QS-15W**

**QS-20W**

Part No. 1275811GT

Rev A

September 2016

---

# Introduction

---

## Important

Read, understand and obey the safety rules and operating instructions in the appropriate Operator's Manual on your machine before attempting any maintenance procedure.

This manual provides detailed scheduled maintenance information for the machine owner and user. It also provides troubleshooting and repair procedures for qualified service professionals.

Basic mechanical, hydraulic and electrical skills are required to perform most procedures. However, several procedures require specialized skills, tools, lifting equipment and a suitable workshop. In these instances, we strongly recommend that maintenance and repair be performed at an authorized Genie dealer service center.

---

## Compliance

### Machine Classification

Group A/Type 1 as defined by ISO 16368

### Machine Design Life

Unrestricted with proper operation, inspection and scheduled maintenance.

---

## Technical Publications

Genie has endeavored to deliver the highest degree of accuracy possible. However, continuous improvement of our products is a Genie policy. Therefore, product specifications are subject to change without notice.

Readers are encouraged to notify Genie of errors and send in suggestions for improvement. All communications will be carefully considered for future printings of this and all other manuals.

---

## Contact Us:

Internet: [www.genielift.com](http://www.genielift.com)  
E-mail: [awp.techpub@terex.com](mailto:awp.techpub@terex.com)

---

## Find a Manual for this Model

Go to <http://www.genielift.com>

Use the links to locate Service Manuals, Maintenance Manuals, Service and Repair Manuals, Parts Manuals and Operator's Manuals.

---

Copyright © 2011 by Terex Corporation

1275811GT Rev A, September 2016

Fourth Edition, First Printing

Genie is a registered trademark of Terex South Dakota, Inc. in the U.S.A. and many other countries.



# Introduction

## Revision History

Revision	Date	Section	Procedure / Page / Description
A	9/2016		Initial release
<b>Reference Examples:</b>			<p style="text-align: center;"><b>Electronic Version</b></p> <p>Click on any content or procedure in the Table of Contents to view the update.</p>
Section – Maintenance Procedure			
Section – Repair Procedure, 4-2			
Section – Fault Codes, All charts			
Section – Schematics, Legends and schematics			



# Introduction

## Serial Number Legend

To August 31, 2016



A TEREK BRAND

**Model:** GR16P-12345      **Serial number:** GR16P-12345

**Manufacture date:** 01/02/2010      **Model year:** 2016

**Elec/Hydr Schematic:**

**Power supply voltage/Pneumatic Pressure:**

**Nominal Power:**

**Machine unladen weight:**

**Max Load:**

**Occupants and Equipment must not exceed:**

**Maximum allowable inclination of the chassis:**

**Maximum Wind Speed:**

**Indoor:**

**Outdoor:**

**Gradeability:**

**Maximum allowable side force:**

**Maximum platform height:**

GR 16 P - 12345

1      2      3      4

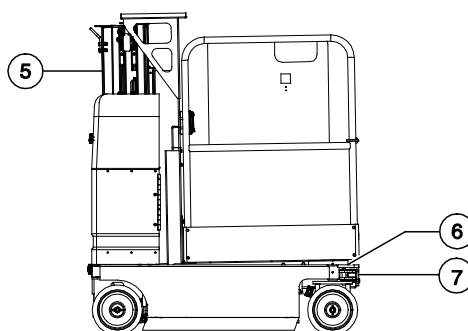

- 1 Model
- 2 Model year
- 3 Facility code
- 4 Sequence number

- 5 Serial label
- 6 Serial number (stamped on chassis, GR models)
- 7 Serial number (stamped on chassis, QS models)

From September 1, 2016



A TEREK BRAND

**Model:** GRP-12345      **Serial number:** GRP-12345

**Year of Manufacture :** 2016

**Elec/Hydr Schematic:**

**Power supply voltage/Pneumatic Pressure:**

**Nominal Power:**

**Machine unladen weight:**

**Max Load:**

**Occupants and Equipment must not exceed:**

**Maximum allowable inclination of the chassis:**

**Maximum Wind Speed:**

**Indoor:**

**Outdoor:**

**Gradeability:**

**Maximum allowable side force:**

**Maximum platform height:**

GR P - 12345

1      2      3

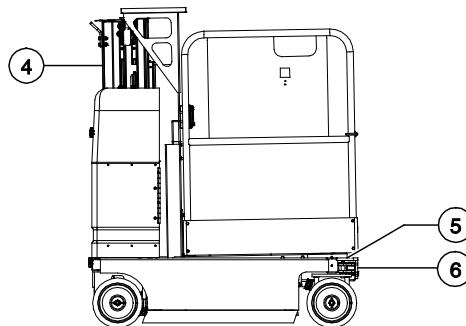

- 1 Model
- 2 Facility code
- 3 Sequence number

- 4 Serial label
- 5 Serial number (stamped on chassis, GR models)
- 6 Serial number (stamped on chassis, QS models)



---

## Safety Rules



### Danger

Failure to obey the instructions and safety rules in this manual and the appropriate Operator's Manual on your machine will result in death or serious injury.

Many of the hazards identified in the operator's manual are also safety hazards when maintenance and repair procedures are performed.

### Do Not Perform Maintenance Unless:

- You are trained and qualified to perform maintenance on this machine.
- You read, understand and obey:
  - manufacturer's instructions and safety rules
  - employer's safety rules and worksite regulations
  - applicable governmental regulations
- You have the appropriate tools, lifting equipment and a suitable workshop.

## Safety Rules

### Personal Safety

Any person working on or around a machine must be aware of all known safety hazards. Personal safety and the continued safe operation of the machine should be your top priority.



Read each procedure thoroughly. This manual and the decals on the machine, use signal words to identify the following:



Safety alert symbol—used to alert personnel to potential personal injury hazards. Obey all safety messages that follow this symbol to avoid possible injury or death.



Indicates a imminently hazardous situation which, if not avoided, will result in death or serious injury.



Indicates a potentially hazardous situation which, if not avoided, could result in death or serious injury.



Indicates a potentially hazardous situation which, if not avoided, may cause minor or moderate injury.



Indicates a potentially hazardous situation which, if not avoided, may result in property damage.



Be sure to wear protective eye wear and other protective clothing if the situation warrants it.



Be aware of potential crushing hazards such as moving parts, free swinging or unsecured components when lifting or placing loads. Always wear approved steel-toed shoes.

### Workplace Safety

Any person working on or around a machine must be aware of all known safety hazards. Personal safety and the continued safe operation of the machine should be your top priority.



Be sure to keep sparks, flames and lighted tobacco away from flammable and combustible materials like battery gases and engine fuels. Always have an approved fire extinguisher within easy reach.



Be sure that all tools and working areas are properly maintained and ready for use. Keep work surfaces clean and free of debris that could get into machine components and cause damage.



Be sure any forklift, overhead crane or other lifting or supporting device is fully capable of supporting and stabilizing the weight to be lifted. Use only chains or straps that are in good condition and of ample capacity.



Be sure that fasteners intended for one time use (i.e., cotter pins and self-locking nuts) are not reused. These components may fail if they are used a second time.



Be sure to properly dispose of old oil or other fluids. Use an approved container. Please be environmentally safe.



Be sure that your workshop or work area is properly ventilated and well lit.

# Table of Contents

<b>Introduction</b>	<b>Introduction..... ii</b> Important Information ..... ii Find a Manual for this Model..... ii Revision History..... iii Serial Number Legend ..... iv
<b>Section 1</b>	<b>Safety Rules ..... v</b> General Safety Rules ..... v
<b>Section 2</b>	<b>Specifications ..... 1</b> Machine Specifications..... 1 Performance Specifications..... 2 Hydraulic Component and Manifold Specifications..... 3 Hydraulic Specification ..... 3 Hydraulic Hose and Fitting Torque Specifications ..... 7 Torque Procedure ..... 8
<b>Section 3</b>	<b>Scheduled Maintenance Procedures ..... 11</b> Introduction..... 11 Maintenance Schedule..... 13 Pre-Delivery Preparation Report ..... 15 Scheduled and Programmed Maintenance Inspection Report ..... 17  <b>Commissioning Procedures..... 19</b> C-1 Perform 40 Hour Service ..... 19



## Table of Contents

<b>Quarterly Maintenance Procedures .....</b>	<b>20</b>
Q-1 Check for Open Bulletins and Owner Registration .....	20
Q-2 Battery Inspection .....	21
Q-3 Inspect the Electrical Wiring.....	24
Q-4 Inspect the Electrical Contactor .....	24
Q-5 Inspect the Voltage Inverter (if equipped) .....	25
Q-6 Test the Flashing Beacons (if equipped) .....	26
Q-7 Test the Alarm Package (if equipped) .....	26
Q-8 Inspect the Tires and Wheels (including castle nut torque).....	27
Q-9 Check the Lifting Chain Adjustments .....	28
Q-10 Clean and Lubricate the Columns .....	28
Q-11 Adjust the Sequencing Cables.....	29
Q-12 Visual Inspection of the Hydraulic Oil .....	30
Q-13 Test the Drive Brakes .....	31
Q-14 Test the Drive Speed – Stowed Position .....	32
Q-15 Test the Drive Speed - Raised Position.....	33
<b>Annual Maintenance Procedures .....</b>	<b>34</b>
A-1 Grease the Platform Overload Mechanism (if equipped).....	34
A-2 Test the Platform Overload System (if equipped) .....	34
<b>Programmed Maintenance Procedures .....</b>	<b>37</b>
P0-1 Grease the Steer Yokes .....	37
P1-1 Inspect the Mast Assembly .....	37
P1-2 Inspect and Lubricate the Lifting Chains .....	38
P2-1 Replace the Hydraulic Filter .....	39
P2-2 Test or Replace the Hydraulic Oil .....	39

# Table of Contents

<b>Section 4</b>	<b>Repair Procedures .....</b>	<b>41</b>
	Introduction.....	41
	<b>Platform Controls .....</b>	<b>43</b>
	1-1 Circuit Board.....	45
	1-2 Joystick.....	46
	1-3 Platform Controls Alarm .....	46
	1-4 Platform Emergency Stop Button.....	47
	<b>Ground Controls.....</b>	<b>48</b>
	2-1 Software Revision Level.....	49
	2-2 Machine Setup .....	50
	2-3 Level Sensors .....	51
	<b>Hydraulic Pump .....</b>	<b>60</b>
	3-1 Hydraulic Pump.....	60
	How to Remove the Hydraulic Pump .....	61
	<b>Function Manifold .....</b>	<b>62</b>
	4-1 Function Manifold Components .....	62
	4-2 Valve Adjustments – Function Manifold.....	64
	4-3 Valve Coils .....	67
	<b>Brake Release Hand Pump Components.....</b>	<b>69</b>
	5-1 Brake Release Hand Pump Components .....	69
	<b>Hydraulic Tank.....</b>	<b>70</b>
	6-1 Hydraulic Tank .....	70
	<b>Non-Steer Axle Components.....</b>	<b>71</b>
	7-1 Drive Brake.....	71



# Table of Contents

<b>Steer Axle Components .....</b>	<b>72</b>
8-1 Yoke and Drive Motor .....	72
8-2 Steer Cylinder .....	73
8-3 Steer Bellcrank .....	74
<b>Platform Components .....</b>	<b>75</b>
9-1 Platform.....	75
9-2 Platform Extension Deck .....	76
9-3 Work Tray .....	77
<b>Mast Components .....</b>	<b>78</b>
10-1 Mast .....	78
How to Disassemble the Mast .....	79
How to Assemble the Mast .....	81
10-2 Glide Pads .....	82
10-3 Lifting Chains .....	83
How to Inspect the Lifting Chains .....	84
10-4 How to Remove the Lift Cylinder .....	86
<b>Platform Overload Components.....</b>	<b>87</b>
11-1 Platform Overload System (if equipped).....	87
11-2 Platform Overload Recovery Message.....	89
<b>Obstruction Sensing System.....</b>	<b>91</b>
12-1 Obstruction Sensing System (QSR models) .....	91
How to Replace an Obstruction Sensing Pad .....	91
<b>Battery Charger .....</b>	<b>93</b>
13-1 Battery Charger .....	93
Selecting a Charge Profile .....	94

# Table of Contents

---

<b>Section 5</b>	<b>Diagnostics .....</b>	<b>95</b>
	Introduction.....	95
	GCON I/O Map without Load Sense .....	97
	GCON I/O Map with Load Sense .....	98
	Operation Indicator Codes (OIC).....	99
	Diagnostic Trouble Codes (DTC) .....	99
	Troubleshooting "HXXX" and "PXXX" Faults .....	100
	Fault Inspection Procedure .....	101
	Type "HXXX" Faults .....	103
	Type "PXXX" Faults.....	104
	Type "UXXX" Faults .....	105
	Type "FXXX" Faults.....	106
	Type "CXXX" Faults .....	107
	Battery Charger .....	108
	Charger Fault Codes.....	109
	Charger Error Codes.....	110

# Table of Contents

<b>Section 6</b>	<b>Schematics .....</b>	<b>115</b>
	Introduction .....	115
	Electrical Component and Wire Color Legends .....	116
	Wiring Diagram Ground and Platform Controls .....	118
	Electrical Symbol Legend .....	119
	Hydraulic Symbols Legend .....	120
	<b>Electrical Schematics – ANSI / CSA Models .....</b>	<b>121</b>
	Electrical Schematic, GR • QSW, ANS / CSA (from serial numbers GR10-20000 to GR11-20683 and QS11-1000 to QS11-1015).....	122
	Electrical Schematic, GR • QSW, ANSI / CSA (from serial numbers GR11-20684 to GR14-29741 and QS11-1016 to QS14-1550).....	126
	Electrical Schematic, GR • QSW, ANSI / CSA (from serial numbers GR14-29742 to GR1540225 and QS14-1551 to QS15-2426).....	130
	Electrical Schemamtic, GR • QSW, ANSI / CSA (from serial numbers GR15-40226 to GR16P-41929 and QS15-2427 to QS16P-2451).....	131
	Electrical Schematic, GR • QSW, ANSI / CSA (from serial numbers GR16P-41930 to GR16P-44173 and QS16P-2452 to QS16P-2468).....	134
	Electrical Schemamtic, GR • QSW, ANSI / CSA (from serial numbers GR16P-44174 to GR16P-46499 and QS16P-2469 to QS16P-4499) (from serial numbers GRP-46500 and QSP-4500).....	135
	Electrical Schematic, QSR, ANSI/CSA (from serial number QS11-1000 - QS11-1015).....	138
	Electrical Schematic, QSR, ANSI/CSA (from serial number QS11-1016 to QS14-1550).....	142
	Electrical Schematic, QSR, ANSI/CSA (from serial number QS14-1551 to QS15-2426).....	146
	Electrical Schematic, QSR, ANSI/CSA (from serial number QS15-2427 to QS16P-2451).....	147
	Electrical Schematic, QSR, ANSI/CSA (from serial number QS16P-2452 to QS16P-2468).....	150
	Electrical Schematic, QSR, ANSI/CSA (from serial number QS16P-2469 to QS16P-4499) (from serial number QSP-4500).....	151

## Table of Contents

<b>Electrical Schematics – AS / CE Models</b> .....	<b>153</b>
Electrical Schematic, GR/QSW, AS/CE (from serial numbers GR10-20000 - GR11-20683 and QS11-1000 - QS11-1015).....	154
Electrical Schematic, GR/QSW, AS/CE (from serial numbers GR11-20684 to GR14-29741 and QS11-1016 to QS14-1550).....	158
Electrical Schematic, GR/QSW, AS/CE (from serial numbers GR14-29742 to GR15-40225 and QS14-1551 to QS15-2426).....	162
Electrical Schematic, GR/QSW, AS/CE (from serial numbers GR15-40226 to GR16P-41929 and QS15-2427 to QS16P-2451).....	163
Electrical Schematic, GR/QSW, AS/CE (from serial numbers GR16P-41930 to GR16P-44173 and QS16P-2452 to QS16P-2468).....	166
Electrical Schematic, GR/QSW, AS/CE (from serial numbers GR16P-44174 to GR16P-46499 and QS16P-2469 to QS16P-4499) (from serial numbers GRP-46500 and QSP-4500).....	167
Electrical Schematic, QSR, AS/CE (from serial number QS11-1000 to QS11-1015).....	170
Electrical Schematic, QSR, AS/CE (from serial number QS11-1016 to QS14-1550).....	174
Electrical Schematic, QSR, AS/CE (from serial number QS14-1551 to QS15-2426).....	178
Electrical Schematic, QSR, AS/CE (from serial number QS15-2427 to QS16P-2451).....	179
Electrical Schematic, QSR, AS/CE (from serial number QS16P-2452 to QS16P-2468).....	182
Electrical Schematic, QSR, AS/CE (from serial number QS16P-2469 to QS16P-4499) (from serial number QSP-4500).....	183
<b>Hydraulic Schematics</b> .....	<b>186</b>
Hydraulic Schematic, GR • QSR • QSW, (from serial numbers GR10-20000 to GR12-24138 and QS11-1000 to QS12-1063).....	186
Hydraulic Schematic GR • QSR • QSW, (from serial numbers GR12-24139 to GR16P-46499 and QS12-1064 to QS16P-4499) (from serial numbers GRP-46500 and QSP-4500).....	187

---

# Table of Contents

This page intentionally left blank

# Specifications

## Machine Specifications

<b>Batteries, Standard</b>	
Voltage	6V DC
Group	GC2
Type	T-105
Quantity	4
Battery capacity, maximum	C20 = 225AH
Reserve capacity @ 25A rate	447 minutes
Weight, each	62 lbs 28 kg
<b>Batteries, Maintenance-free (option)</b>	
Voltage	6V DC
Group	GC2
Type	6V-AGM
Quantity	4
Battery capacity, maximum	C20 = 200AH
Reserve capacity @ 25A rate	380 minutes
Weight, each	62 lbs 28 kg
<b>DC Motor</b>	
Voltage	24V
Horsepower	4.5 HP @ 2950 rpm
Kilowatts	3.3 kW @ 2950 rpm
<b>Fluid capacities</b>	
Hydraulic tank	3.75 gallons 14.2 liters
Hydraulic system (including tank)	5 gallons 19 liters

<b>Height, stowed maximum</b>	
GR-12, GR-15, QS-12R, QS-15R, QS-12W and QS15W (ANSI / CSA models)	62 in 1.57 m
GR-12, GR-15, QS-12R, QS-15R, QS-12W and QS15W (AS / CE models)	68.1 in 1.73 m
GR-20, QS-20R, QS-20W	78 in 1.98 m
<b>Tires and wheels</b>	
Tire size (solid rubber)	10 x 3 in 25.4 x 7.62 cm
Tire contact area	6.5 sq in 41.9 cm <sup>2</sup>
Castle nut torque, lubricated	150 ft-lbs 203 Nm

# Specifications

## Performance Specifications

### Drive speed, maximum

Platform stowed, fast	2.5 mph
	40 ft / 10.9 sec
	4 km/h 12.2 m / 10.9 sec
Platform stowed, slow	1.1 mph
	40 ft / 24.8 sec
	1.8 km/h 12.2 m / 24.8 sec
Platform raised	0.5 mph
	40 ft / 55 sec
	0.8 km/h 12.2 m / 55 sec

### Braking distance, maximum

High range on paved surface	19 in ± 6 in 61 cm ± 30 cm
-----------------------------	-------------------------------

### Gradeability **See Operator's Manual**

### Function speed, maximum from platform controls (with 1 person in platform)

#### GR-12, QS-12R, QS-12W

Platform up (fast mode)	19 to 21 seconds
Platform up (slow mode)	30 to 32 seconds
Platform down	17 to 19 seconds

#### GR-15, QS-15R, QS-15W

Platform up (fast mode)	20 to 22 seconds
Platform up (slow mode)	31 to 33 seconds
Platform down	18 to 20 seconds

#### GR-20, QS-20R, QS-20W

Platform up (fast mode)	23 to 25 seconds
Platform up (slow mode)	32 to 34 seconds
Platform down	20 to 22 seconds

### Rated work load at full height, maximum

<b>GR-12, GR-15</b> (standard platform)	500 lbs 227 kg
<b>GR-12, GR-15, GR-20</b> (AWP platform)	350 lbs 159 kg
<b>GR-20</b> (standard platform)	350 lbs 159 kg
<b>QS-12R, QS-15R, QS-12W, QS-15W</b> (stockpicker platform)	500 lbs 227 kg
<b>QS-20R, QS-20W</b> (stockpicker platform)	350 lbs 159 kg

**For operational specifications, refer to the Operator's Manual.**

# Specifications

## Hydraulic Component Specifications

### Function pump

Type	Gear
Displacement per revolution	0.244 cu in 4 cc
Flow rate @ 2500 psi / 172 bar	4 gpm 15 L/min
Hydraulic tank return filter	10 micron with 25 psi / 1.7 bar bypass

### Function manifold

System relief valve pressure, maximum	3500 psi 241 bar
Lift relief valve pressure	1800 to 3500 psi 124 to 241 bar
Steer relief valve pressure	1500 psi 103 bar

## Manifold Component Specifications

### Plug torque

SAE No. 2	50 in-lbs / 6 Nm
SAE No. 4	13 ft-lbs / 18 Nm
SAE No. 6	18 ft-lbs / 24 Nm
SAE No. 8	50 ft-lbs / 68 Nm
SAE No. 10	55 ft-lbs / 75 Nm
SAE No. 12	75 ft-lbs / 102 Nm

## Hydraulic Oil Specifications

### Hydraulic Fluid Specifications

Genie specifications require hydraulic oils which are designed to give maximum protection to hydraulic systems, have the ability to perform over a wide temperature range, and the viscosity index should exceed 140. They should provide excellent antiwear, oxidation prevention, corrosion inhibition, seal conditioning, and foam and aeration suppression properties.

Cleanliness level, minimum	ISO 15/13
----------------------------	-----------

Water content, maximum	250 ppm
------------------------	---------

### Recommended Hydraulic Fluid

Hydraulic oil type	Chevron Rando HD Premium
Viscosity grade	32
Viscosity index	200

### Optional Hydraulic Fluids

Mineral based	Shell Tellus S2 V 32 Shell Tellus S2 V 46 Shell Tellus S4 VX 32 Shell Shell Donax TG (Dexron III) Chevron 5606A
---------------	---

Biodegradable	Petro Canada Environ MV 46
---------------	----------------------------

Fire resistant	UCON Hydrolube HP-5046
----------------	------------------------

Note: Genie specifications require additional equipment and special installation instructions for the approved optional fluids. Consult Genie Product Support before use.

### NOTICE

Optional fluids may not have the same hydraulic lifespan and may result in component damage.

Note: Extended machine operation can cause the hydraulic fluid temperature to increase beyond its maximum allowable range. If the hydraulic fluid temperature consistently exceeds 200°F / 90°C an optional oil cooler may be required.

# Specifications

## NOTICE

Do not top off with incompatible hydraulic fluids. Hydraulic fluids may be incompatible due to the differences in base additive chemistry. When incompatible fluids are mixed, insoluble materials may form and deposit in the hydraulic system, plugging hydraulic lines, filters, control valves and may result in component damage.

Note: Do not operate the machine when the ambient air temperature is consistently above 120°F / 49°C.

## Hydraulic Fluid Temperature Range

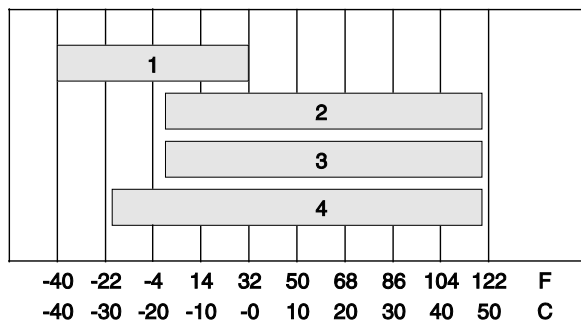

Ambient air temperature

- 1 Chevron hydraulic oil 5606A
- 2 Petro-Canada Environ MV 46
- 3 UCON Hydrolube HP-5046D
- 4 Chevron Rando HD premium oil MV

## Chevron Rando HD Premium Oil MV Fluid Properties

ISO Grade	32
Viscosity index	200
Kinematic Viscosity	
cSt @ 200°F / 100°C	7.5
cSt @ 104°F / 40°C	33.5
Brookfield Viscosity	
cP @ -4°F / -20°C	1040
cP @ -22°F / -30°C	3310
Flash point	375°F / 190°C
Pour point	-58°F / -50°C
Maximum continuous operating temperature	171°F / 77°C

Note: A hydraulic oil heating system is recommended when the ambient temperature is consistently below 0°F / -18°C.

Note: Do not operate the machine when the ambient temperature is below -20°F / -29°C with Rando HD Premium MV.

## Specifications

### Chevron 5606A Hydraulic Oil Fluid Properties

ISO Grade	15
Viscosity index	300
Kinematic Viscosity	
cSt @ 200°F / 100°C	5.5
cSt @ 104°F / 40°C	15.0
cSt @ -40°F / -40°C	510
Flash point	180°F / 82°C
Pour point	-81°F / -63°C
Maximum continuous operating temperature	124°F / 51°C

Note: Use of Chevron 5606A hydraulic fluid, or equivalent, is required when ambient temperatures are consistently below 0°F / -17°C unless an oil heating system is used.

#### NOTICE

Continued use of Chevron 5606A hydraulic fluid, or equivalent, when ambient temperatures are consistently above 32°F / 0°C may result in component damage

### Petro-Canada Environ MV 46 Fluid Properties

ISO Grade	46
Viscosity index	154
Kinematic Viscosity	
cSt @ 200°F / 100°C	8.0
cSt @ 104°F / 40°C	44.4
Flash point	482°F / 250°C
Pour point	-49°F / -45°C
Maximum continuous operating temperature	180°F / 82°C

### Shell Tellus S4 VX Fluid Properties

ISO Grade	32
Viscosity index	300
Kinematic Viscosity	
cSt @ 200°F / 100°C	9
cSt @ 104°F / 40°C	33.8
Brookfield Viscosity	
cSt @ -4°F / -20°C	481
cSt @ -13°F / -25°C	702.4
cSt @ -40°F / -40°C	2624
Flash point	>100
Pour point	-76°F / -60°C
Maximum continuous operating temperature	103°F / 75°C

---

# Specifications

## UCON Hydrolube HP-5046 Fluid Properties

ISO Grade	46
Viscosity index	192
Kinematic Viscosity	
cSt @ 149°F / 65°C	22
cSt @ 104°F / 40°C	46
cSt @ 0°F / -18°C	1300
Flash point	None
Pour point	-81°F / -63°C
Maximum continuous operating temperature	189°F / 87°C

## Specifications

### Hydraulic Hose and Fitting Torque Specifications

Your machine is equipped with Parker Seal-Lok™ ORFS or 37° JIC fittings and hose ends. Genie specifications require that fittings and hose ends be torqued to specification when they are removed and installed or when new hoses or fittings are installed.

#### Seal-Lok™ Fittings

(hose end - ORFS)

SAE Dash Size	Torque
-4	10 ft-lbs / 13.6 Nm
-6	30 ft-lbs / 40.7 Nm
-8	40 ft-lbs / 54.2 Nm
-10	60 ft-lbs / 81.3 Nm
-12	85 ft-lbs / 115 Nm
-16	110 ft-lbs / 150 Nm
-20	140 ft-lbs / 190 Nm
-24	180 ft-lbs / 245 Nm

#### JIC 37° Fittings

(swivel nut or hose connection)

SAE Dash Size	Thread Size	Flats
-4	7/16-20	2
-6	9/16-18	1 ¼
-8	3/4-16	1
-10	7/8-14	1
-12	1 1/16-12	1
-16	1 5/16-12	1
-20	1 5/8-12	1
-24	1 7/8-12	1

#### SAE O-ring Boss Port

(tube fitting - installed into Aluminum)  
(all types)

SAE Dash Size	Torque
-4	14 ft-lbs / 19 Nm
-6	23 ft-lbs / 31.2 Nm
-8	36 ft-lbs / 54.2 Nm
-10	62 ft-lbs / 84 Nm
-12	84 ft-lbs / 114 Nm
-16	125 ft-lbs / 169.5 Nm
-20	151 ft-lbs / 204.7 Nm
-24	184 ft-lbs / 249.5 Nm

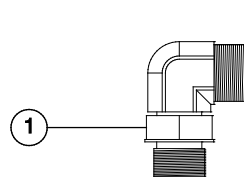

Adjustable Fitting

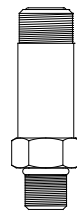

Non-adjustable fitting

1 jam nut

#### SAE O-ring Boss Port

(tube fitting - installed into Steel)

SAE Dash Size	Torque
-4 ORFS / 37° (Adj)	15 ft-lbs / 20.3 Nm
ORFS (Non-adj)	26 ft-lbs / 35.3 Nm
37° (Non-adj)	22 ft-lbs / 30 Nm
-6 ORFS (Adj / Non-adj)	35 ft-lbs / 47.5 Nm
37° (Adj / Non-adj)	29 ft-lbs / 39.3 Nm
-8 ORFS (Adj / Non-adj)	60 ft-lbs / 81.3 Nm
37° (Adj / Non-adj)	52 ft-lbs / 70.5 Nm
-10 ORFS (Adj / Non-adj)	100 ft-lbs / 135.6 Nm
37° (Adj / Non-adj)	85 ft-lbs / 115.3 Nm
-12 (All types)	135 ft-lbs / 183 Nm
-16 (All types)	200 ft-lbs / 271.2 Nm
-20 (All types)	250 ft-lbs / 339 Nm
-24 (All types)	305 ft-lbs / 413.5 Nm

# Specifications

## Torque Procedure

### Seal-Lok™ fittings

- 1 Replace the O-ring. The O-ring must be replaced anytime the seal has been broken. The O-ring cannot be re-used if the fitting or hose end has been tightened beyond finger tight.

Note: The O-ring in Parker Seal Lok™ fittings and hose end are custom-size O-rings. They are not standard size O-rings. They are available in the O-ring field service kit (Genie part number 49612).

- 2 Lubricate the O-ring before installation.
- 3 Be sure the O-ring face seal is seated and retained properly.
- 4 Position the tube and nut squarely on the face seal end of the fitting, and tighten the nut finger tight.
- 5 Tighten the nut or fitting to the appropriate torque. Refer to the appropriate torque chart in this section.
- 6 Operate all machine functions and inspect the hose, fittings and related components to confirm there are no leaks.

### JIC 37° fittings

- 1 Align the tube flare (hex nut) against the nose of the fitting body (body hex fitting) and tighten the hex nut to the body hex fitting to hand tight, approximately 30 in-lbs / 3.4 Nm.
- 2 Using a permanent ink marker, make a reference mark on one the flats of the hex nut and continue the mark onto the body of the hex fitting. Refer to Illustration 1.

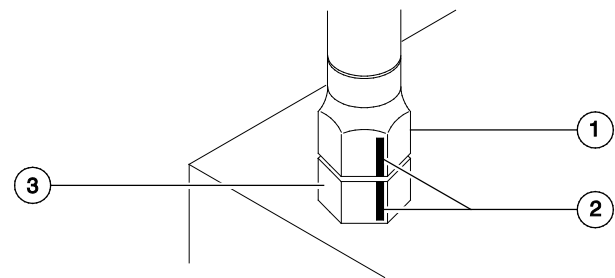

Illustration 1

- 1 hex nut
- 2 reference mark
- 3 body hex fitting

## Specifications

- 3 Working clockwise on the body hex fitting, make a second mark with a permanent ink marker to indicate the proper tightening position. Refer to Illustration 2.

Note: Use the JIC 37° Fitting table in this section to determine the correct number of flats, for the proper tightening position.

Note: The marks indicate the correct tightening positions have been determined. Use the second mark on the body hex fitting to properly tighten the joint after it has been loosened.

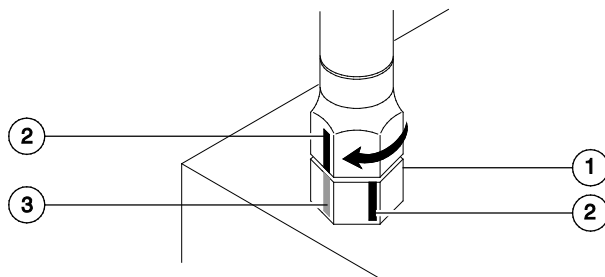

Illustration 2

- 1 body hex fitting
- 2 reference mark
- 3 second mark

- 4 Tighten the hex nut until the mark on the hex nut is aligned with the second mark on the body hex fitting.
- 5 Operate all machine functions and inspect the hose, fittings and related components to confirm there are no leaks.

This page intentionally left blank.

## Scheduled Maintenance Procedures



### Observe and Obey:

- ☑ Maintenance inspections shall be completed by a person trained and qualified on the maintenance of this machine.
- ☑ Scheduled maintenance inspections shall be completed daily, quarterly, semi-annually, annually and every 2 years as specified of the *Maintenance inspection Report*. The frequency and extent of periodic examinations and tests may also depend on national regulations.

### **⚠ WARNING**

Failure to perform each procedure as presented and scheduled may cause death, serious injury or substantial damage.

- ☑ Immediately tag and remove from service a damaged or malfunctioning machine.
- ☑ Repair any machine damage or malfunction before operating the machine.
- ☑ Use only Genie approved replacement parts.
- ☑ Machines that have been out of service for a period longer than 3 months must complete the quarterly inspection.

### Machine Configuration:

- ☑ Unless otherwise specified, perform each procedure with the machine in the following configuration:
  - Machine parked on a firm, level surface
  - Key switch in the off position with the key removed
  - The red Emergency Stop button in the off position at both the ground and platform controls
  - Wheels chocked
  - All external AC power supply disconnected from the machine
  - Platform in the stowed position

# Scheduled Maintenance Procedures

## About This Section

This section contains detailed procedures for each scheduled maintenance inspection.

Each procedure includes a description, safety warnings and step-by-step instructions.

## Symbols Legend



Safety alert symbol—used to alert personnel to potential personal injury hazards. Obey all safety messages that follow this symbol to avoid possible injury or death.



Indicates a imminently hazardous situation which, if not avoided, will result in death or serious injury.



Indicates a potentially hazardous situation which, if not avoided, could result in death or serious injury.



Indicates a potentially hazardous situation which, if not avoided, may cause minor or moderate injury.



Indicates a potentially hazardous situation which, if not avoided, may result in property damage.

- ⊙ Indicates that a specific result is expected after performing a series of steps.
- ⊗ Indicates that an incorrect result has occurred after performing a series of steps.

## Maintenance Symbols Legend

Note: The following symbols have been used in this manual to help communicate the intent of the instructions. When one or more of the symbols appear at the beginning of a maintenance procedure, it conveys the meaning below.



Indicates that tools will be required to perform this procedure.



Indicates that new parts will be required to perform this procedure.



Indicates that dealer service will be required to perform this procedure.



Indicates that a cold motor or pump will be required to perform this procedure.

# Scheduled Maintenance Procedures

## Maintenance Schedule

The maintenance procedures have been divided into subsections that include: Commissioning, Quarterly, Annually and Programmed maintenance intervals. The maintenance inspection report has been divided into general areas of the machine that include: Drive Chassis, Platform, Mast, Functions and Controls, and Electrical.

Failure to perform these procedures may result in poor performance, component damage and unsafe operating conditions. They are essential to safe operation, machine performance and service life.

**Commissioning:** A series of required one time maintenance procedures to be performed at 50 and 150 hour intervals.

**Quarterly and Annually:** A series of maintenance procedures to be performed quarterly or annually.

**Programmed:** A series of maintenance procedures to be performed during a Pre-Delivery Preparation or based on machine operating hours.

## Maintenance Inspection Report

The maintenance inspection report contains checklists for each type of scheduled inspection.







Make copies of the *Maintenance Inspection Report* to use for each inspection. Maintain completed forms for a minimum of 4 years or in compliance with your employer, jobsite and governmental regulations and requirements.

### Instruction Examples









#### Commissioning Example:

<b>Commissioning</b>		 50	 150
 Engine - all models	 PO-1		





#### Quarterly and Annually Example:

 <b>Drive Chassis</b>	 <b>Intervals</b>	Q	A
 Inspect the tires, wheels and Lug Nut Torque	 Q-4		 $\emptyset$

#### Programmed Example (under 1000 HRS):

<b>Programmed Maintenance - Under 1000 HRS</b>		Status	Enter Hours
 Check Track Tension/Fastener Torque	 PO-1		 50
 Engines - Deutz Under 1000 HRS	 PO-2		

#### Programmed Example:

<b>Programmed Maintenance</b>	 Hours are in thousands					
<b>All models</b>	1	2	3	4	6	12
 Engine - all models, 1000 hrs	 P1-1		$\emptyset$	$\emptyset$	$\emptyset$	$\emptyset$

### Instructions Legend

Use the following detailed descriptions to identify the intended use of the maintenance inspection reports.

-  Specific Interval: blank box is the interval to be completed and the  $\emptyset$  marks the interval as not required.

---

-  The description of the procedure or checklist to be completed.

---

-  The procedure number or checklist to be completed.

---

-  Check box to indicate status of inspection.

---

-  Specific interval is not required for this procedure.

---

-  General area of the machine to complete the procedure.

---

-  If this box has a designated time interval: this is the specific time interval to complete the procedure or checklist.

If this box is empty: the maintenance checklist will include multiple time intervals, use this box to write in the specific interval for the inspection completed.

This page intentionally left blank.

# Pre-Delivery Preparation Report

## Fundamentals

It is the responsibility of the owner or dealer to perform the Pre-delivery Preparation.

The Pre-delivery Preparation is performed prior to each delivery. The inspection is designed to discover if anything is apparently wrong with a machine before it is put into service.

A damaged or modified machine must never be used. If damage or any variation from factory delivered condition is discovered, the machine must be tagged and removed from service.

Repairs to the machine may only be made by a qualified service technician, according to the manufacturer's specifications.

Scheduled maintenance inspections shall be performed by qualified service technicians, according to the manufacturer's specifications and the requirements listed in the responsibilities manual.

## Instructions

Use the operator's manual on your machine.

The Pre-delivery Preparation consists of completing the Pre-operation Inspection, the Maintenance items and the Function Tests.

Use this form to record the results. Place a check in the appropriate box after each part is completed. Follow the instructions in the operator's manual.

If any inspection receives an N, remove the machine from service, repair and re-inspect it. After repair, place a check in the R box.

### Legend

- Y = yes, acceptable
- N = no, remove from service
- R = repaired

### Comments

Pre-delivery Preparation	Y	N	R
Pre-operation inspection completed			
Maintenance items completed			
Function tests completed			

Model

Serial number

Date

Machine owner

Inspected by (print)

Inspector signature

Inspector title

Inspector company



**Terex South Dakota, Inc USA**  
 500 Oak Wood Road  
 PO Box 1150  
 Watertown, SD 57201-6150  
 (605) 882-4000

**Genie UK**  
 The Maltings, Wharf Road  
 Grantham, Lincolnshire  
 NG31- 6BH England  
 (44) 1476-584333

This page intentionally left blank.

Model		Hour meter	Date
Serial number		Inspector company	Machine owner
Inspected by (print)		Inspector signature	
<b>Scheduled Maintenance:</b> Inspection Type Q = quarterly or frequent inspections A = annual inspections	<b>Legend</b> Y = yes, acceptable N = no, remove from service R = repaired ∅ = not applicable	Make copies of this report to use for each inspection. Select the appropriate procedures for the type of inspection(s) to perform.	<b>Programmed Maintenance:</b> Programmed maintenance will be completed based on machine hours. This program includes the onetime or commissioning procedures for new products. The onetime procedures will be completed at 50 or 150 hours.

If any inspection receives an "N," tag and remove the machine from service, repair and re-inspect it. After repair, place a "R" in the box.

Drive Chassis	Intervals	Q	A
Inspect the Tires, Wheels and Castle Nut Torque	Q-8		
Chassis Mechanicals and Hydraulics	Intervals	Q	A
Visual Inspection of the Hydraulic Oil	Q-12		
Electrical	Intervals	Q	A
Battery Inspection	Q-2		
Inspect the Electrical Wiring	Q-3		
Inspect the Electrical Contactor	Q-4		
Inspect the Voltage Inverter - (if equipped)	Q-5		
Mast		Q	A
Check the Lifting Chain Adjustments	Q-9		
Clean and Lubricate the Columns	Q-10		
Adjust the Sequencing Cables	Q-11		
Platform	Intervals	Q	A
Grease the Platform Overload Mechanism	A-1	∅	
Test the Platform Overload System	A-2	∅	
Functions and Controls	Intervals	Q	A
Check for Open Bulletins and Owner Registration	Q-1		
Test the Flashing Beacons (if equipped)	Q-6		
Test the Alarm Package	Q-7		
Test the Drive Brakes	Q-13		
Test Drive Speed – Stowed Position	Q-14		
Test Drive Speed – Raised Position	Q-15		
Test the Slow Drive Speed	Q-16		

<b>Commissioning</b>			50
50 Hour Service - all models	C-1		
Programmed Maintenance - Under 1000 HRS		Status	Enter Hours
Grease the Steer Yokes	P0-1		100
Programmed Maintenance		Hours are in thousands	
All models	Perform every:	1	2
Inspect Mast Assembly for Wear	P1-1		∅
Inspect and Lubricate the Lifting Chains	P1-2		∅
Replace the Hydraulic Filters	P2-1	∅	
Test or Replace the Hydraulic Oil	P2-2	∅	

This page intentionally left blank.

---

# Commissioning Procedures

## C-1

### Perform 50 Hour Service



The 50 hour maintenance procedure is a one time sequence of procedures to be performed after the first 50 hours of usage. After this interval, refer to the maintenance inspection report for continued scheduled maintenance.

- 1 Perform the following maintenance procedures:

**All Models:**

Q-8 Inspect the Tires, Wheels and Castle Nut Torque

P2-1 Replace the Hydraulic Filters

# Quarterly Maintenance Procedures

## Q-1 Check for Open Bulletins and Owner Registration



Genie specifications require that this procedure be performed quarterly.

Completing required bulletins is essential to safe machine operation. An important way to ensure your machine has no open bulletins is to frequently check the serial number of your Genie machine against our bulletin database. Using the links below you can view any open bulletins for your machine(s) that require mandatory and immediate work to be completed.

Note: If you are unable to access this information on our websites, please contact your local Genie representative using the contact information provided on the back cover of this manual.

- 1 Locate the serial number plate or label on your machine and document your Genie machine serial number (exactly as its displayed on the serial plate or label).
- 2 Confirm that Genie has the current machine owner information on file by contacting our warranty department at 1-800-536-1800 or use the link included in this procedure to download and complete a New Owner Registration Form.
- 3 Using the link provided, check for current bulletins for your machine(s).

### Machines purchased in Australia:

Go to [Australia Bulletins](http://genielift.com.au/contact)  
(<http://genielift.com.au/contact>)

- 1 Contact any one of the Genie Service centers around Australia to arrange for factory trained technicians to attend to your equipment needs.

### Machines purchased in ASIA, North America and Latin America:

Go to [ASIA, North America and Latin America Bulletins](https://www.gogenielift.com/)  
(<https://www.gogenielift.com/>)



- 1 Select "Customer Login" to login or select "Request New Access" to create a new account.
- 2 At the homepage, select "Unit Configuration" and enter your machine serial number.
- 3 Press the "Lookup" button to view your machine configuration and to check for open bulletins.
- 4 Complete all required bulletins shown for your specific machine serial number.

### Machines purchased in Europe, Middle East, Africa, and Russia:

Go to [EMEAR Bulletins](http://www.genielift.co.uk/en/sales-and-support/bulletin-campaigns/index.htm)  
(<http://www.genielift.co.uk/en/sales-and-support/bulletin-campaigns/index.htm>)



- 1 Enter your machine serial number and press search to check for open bulletins.
- 2 Complete all required bulletins shown for your specific machine serial number.

## Quarterly Maintenance Procedures

### Q-2 Battery Inspection



Genie specifications require that this procedure be performed quarterly.

Proper battery condition is essential to good engine and machine performance and operational safety. Improper fluid levels or damaged cables and connections can result in engine and component damage and hazardous conditions.

**⚠ WARNING** Electrocutation/burn hazard. Contact with electrically charged circuits could result in death or serious injury. Remove all rings, watches and other jewelry.

**⚠ WARNING** Bodily injury hazard. Batteries contain acid. Avoid spilling or contacting battery acid. Neutralize battery acid spills with baking soda and water.

Note: Fully charge the batteries and allow the batteries to rest 24 hours before performing this procedure to allow the battery cells to equalize.

- 1 **GR-12, QS-12R, QS-12W:** Raise the platform approximately 3 feet / 1 m.  
**GR-15, GR-20, QS-15R, QS-20R, QS-15W, QS-20W:** Raise the platform approximately 5 feet / 1.5 m.
- 2 Open the battery cover. Rest the cover against the chassis.

- 3 Lower the platform until the mast just contacts the battery cover.

**⚠ WARNING** Crushing hazard. Keep hands clear of the battery cover when lowering the platform.

- 4 Be sure that the battery cable connections are free of corrosion.

Note: Adding terminal protectors and a corrosion preventative sealant will help eliminate corrosion on the battery terminals and cables.

- 5 Be sure that the battery retainers and cable connections are tight.
- 6 Be sure that the battery separator wire connections are tight (if equipped).

#### Models without maintenance-free or sealed batteries:

- 7 Put on protective clothing and eye wear.
- 8 Remove the battery vent caps and check the specific gravity of each battery cell with a hydrometer. Note the results.
- 9 Check the ambient air temperature and adjust the specific gravity reading for each cell as follows:
  - Add 0.004 to the reading of each cell for every 10° F / 5.5° C above 80° F / 26.7° C.
  - Subtract 0.004 from the reading of each cell for every 10° F / 5.5° C below 80° F / 26.7° C.
- Result: All battery cells display an adjusted specific gravity of 1.277 or higher. The battery is fully charged. Proceed to step 11.
- ⊗ Result: One or more battery cells display a specific gravity of 1.276 or below. Proceed to step 8.

## Quarterly Maintenance Procedures

- 10 Perform an equalizing charge OR fully charge the battery(s) and allow the battery(s) to rest at least 6 hours.
- 11 Remove the battery vent caps and check the specific gravity of each battery cell with a hydrometer. Note the results.
- 12 Check the ambient air temperature and adjust the specific gravity reading for each cell as follows:
  - Add 0.004 to the reading of each cell for every 10° F / 5.5° C above 80° F / 26.7° C.
  - Subtract 0.004 from the reading of each cell for every 10° F / 5.5° C below 80° F / 26.7° C.
- 14 Install the vent caps and neutralize any electrolyte that may have spilled.
- 15 Check each battery pack and verify that the batteries are wired correctly.

- 12 Check the ambient air temperature and adjust the specific gravity reading for each cell as follows:

- Add 0.004 to the reading of each cell for every 10° F / 5.5° C above 80° F / 26.7° C.
- Subtract 0.004 from the reading of each cell for every 10° F / 5.5° C below 80° F / 26.7° C.

- ⊙ Result: All battery cells display a specific gravity of 1.277 or greater. The battery is fully charged. Proceed to step 11.
- ⊗ Result: One or more battery cells display a specific gravity from 1.218 to 1.269. The battery is still usable, but at a lower performance. The battery will need to be recharged more often. Proceed to step 11.
- ⊗ Result: One or more battery cells display a specific gravity from 1.217 to 1.173. The battery is approaching the end of its life. Proceed to step 11.
- ⊗ Result: The difference in specific gravity readings between cells is greater than 0.1 OR the specific gravity of one or more cells is less than 1.177. Replace the battery.

- 13 Check the battery acid level. If needed, replenish with distilled water to 1/8 inch / 3 mm below the bottom of the battery fill tube. Do not overfill.

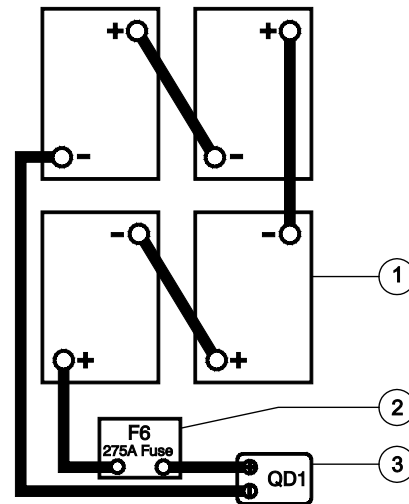

- 1 batteries B5
- 2 275A fuse F6
- 3 quick disconnect QD1

- 16 Inspect the battery charger plug and pigtail for damage or excessive insulation wear. Replace as required.

---

## Quarterly Maintenance Procedures

17 Connect the battery charger to a properly grounded 115V/60Hz or, 230V/60Hz or 50Hz single phase AC power supply.

- ⦿ Result: The charger should operate and begin charging the batteries.

If, simultaneously, the charger alarm sounds and the LEDs blink one time, correct the charger connections at the fuse and battery. The charger will then operate correctly and begin charging the batteries.

If, simultaneously, the charger alarm sounds and the LEDs blink two times, the input voltage is too low or too high. Correct the voltage issue. The charger will then operate correctly and begin charging the batteries.

If, simultaneously, the charger alarm sounds and the LEDs blink three times, the charger is overheated. Allow the charger to cool. The charger will then operate correctly and begin charging the batteries.

Note: For best results, use an extension of adequate size with a length no longer than 50 feet / 15 m.

Note: If you have any further questions regarding the battery charger operation, please contact Genie Product Support.

## Quarterly Maintenance Procedures

### Q-3 Inspect the Electrical Wiring



Genie specifications require that this procedure be performed quarterly.

Maintaining electrical wiring in good condition is essential to safe operation and good machine performance. Failure to find and replace burnt, chafed, corroded or pinched wires could result in unsafe operating conditions and may cause component damage.

**⚠ WARNING** Electrocutation/burn hazard. Contact with electrically charged circuits could result in death or serious injury. Remove all rings, watches and other jewelry.

- 1 Inspect the underside of the chassis for damaged or missing ground straps.
- 2 Inspect the following areas for burnt, chafed, corroded pinched and loose wires:
  - All wire harness connectors to ground control box
  - Ground control panel
  - Hydraulic power unit
  - All wire harness connectors to platform control box
  - Platform controls
  - Power to platform wiring
  - Harness connections
  - Hydraulic manifold wiring
  - Contactor
  - Limit switches
- 3 Inspect for a lite, even coating of dielectric grease on all harness connections.

Note: Do not apply excessive amounts of dielectric grease to harness connectors, pins or sockets.

### Q-4 Inspect the Electrical Contactor



Genie specifications require that this procedure be performed quarterly.

Maintaining the electrical contactor in good condition is essential to safe machine performance. Failure to locate a worn or damaged contactor could result in unsafe operating conditions and may cause component damage.

**⚠ WARNING** Electrocutation/burn hazard. Contact with electrically charged circuits could result in death or serious injury. Remove all rings, watches and other jewelry.

- 1 At the ground controls, turn the key switch to the off position.
- 2 Push in the red Emergency Stop button at the ground controls to the off position.
- 3 At the non-steer end of the machine, open the cover to access the electrical tray.
- 4 Locate and disconnect the Anderson connector.
- 5 Locate the electrical contactor mounted on the fuse bracket.
- 6 Visually inspect the contact points of the contactor for the following items:
  - Excessive burns
  - Excessive arcs
  - Excessive pitting

Note: Replace the contactor if any damage is found.

## Quarterly Maintenance Procedures

### Q-5 Inspect the Voltage Inverter (if equipped)



Genie specifications require that this procedure be performed quarterly.

Perform this procedure more often if dusty conditions exist.

- 1 Inspect the inverter plug and pigtail for damage or excessive insulation wear. Replace as required.
- 2 Turn the key switch to the on position and pull out the red Emergency Stop button to the on position at both the ground and platform controls.

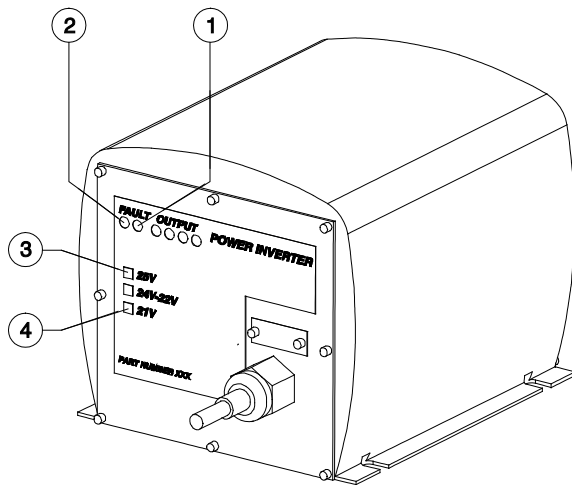

- 1 right fault LED
- 2 left fault LED
- 3 25V LED
- 4 21V LED

- 3 Connect an appropriate power tool to the inverter. Activate the tool.
  - Result: The power tool should operate. There may be a brief (0.5 second) delay if the power tool has not been used in the previous 10 minutes.
  - ✘ If the left fault LED (REV\_POL) is illuminated, the inverter is connected to batteries with the incorrect polarity. Correct the polarity issue with the red wire to battery positive and the black wire to battery negative. The inverter will then operate correctly and begin supplying AC power.
  - ✘ If the right fault LED (123) blinks one time, the power draw is too high. The tool being used requires too much power to operate or is being used at or near the limit of the inverter for an extended period of time. Reduce the power draw. The inverter will then operate correctly and begin supplying AC power.
  - ✘ If the right fault LED (123) blinks two times, the Ground Fault Interrupt (GFI) has been activated. A short circuit or partial short exists between the AC hot and ground in the tool or outlet. Check the tool for burnt, chafed, corroded and loose wires, and inspect the tool for internal moisture. Correct the short circuit or moisture issue OR inspect the wiring in the power-to-platform box. The inverter will then operate correctly and begin supplying AC power.
  - ✘ If right fault LED (123) blinks three times, the inverter is overheated. Allow the inverter to cool. The inverter will then operate correctly and begin supplying AC power.
  - ✘ If the battery 25 volt fault LED (25V) blinks one time, the battery voltage is over 30V. Operate the machine to lower the voltage level. The inverter will then operate correctly and begin supplying AC power.
  - ✘ If the battery 21 volt fault LED (21V) blinks one time, the battery voltage is less than 20V DC. The inverter will continue to operate until the battery voltage falls to 17.8V DC.

---

## Quarterly Maintenance Procedures

### Q-6 Test the Flashing Beacons (if equipped)

Genie specifications require that this procedure be performed quarterly.

Flashing beacons are used to alert operators and ground personnel of machine proximity and motion. The flashing beacons are located on both sides of the machine.

- 1 Turn the key switch to ground control and pull out the red Emergency Stop button to the on position at both ground and platform controls.
  - ⦿ Result: The beacons should flash.
- 2 Turn the key switch to platform controls.
  - ⦿ Result: The beacons should flash.

### Q-7 Test the Alarm Package (if equipped)

Genie specifications require that this procedure be performed quarterly.

Alarms are used to alert operators and ground personnel of machine proximity and motion. The motion alarm is located in the ground control box and, when activated, will sound at 60 beeps per minute.

- 1 Turn the key switch to ground control and pull out the red Emergency Stop button to the on position at both ground and platform controls.
- 2 Press and hold the high speed lift enable button.
- 3 Press the platform up button and raise the platform approximately 1 foot / .3 m.
- 4 Press the platform down button and lower the platform to the stowed position.
  - ⦿ Result: The alarm should sound when the platform is in motion.
- 5 Press and hold the low speed lift enable button.
- 6 Press the platform up button and raise the platform approximately 1 foot / .3 m.
- 7 Press the platform down button and lower the platform to the stowed position.
  - ⦿ Result: The alarm should sound when the platform is in motion.

## Quarterly Maintenance Procedures

- 8 Turn the key switch to platform controls.
- 9 Press and hold the high speed lift enable button.
- 10 Press the platform up button and raise the platform approximately 4 feet / .2 m.
- 11 Press the platform down button and lower the platform to the stowed position.
  - ⊙ Result: The alarm should sound when the platform is in motion.
- 12 Press and hold the low speed lift enable button.
- 13 Press the platform up button and raise the platform approximately 4 feet / .2 m.
- 14 Press the platform down button and lower the platform to the stowed position.
  - ⊙ Result: The alarm should sound when the platform is in motion.
- 15 Press and hold the drive/steer function enable switch on the control handle. Move the control handle off center, hold for a moment and then release it. Move the control handle off center in the opposite direction, hold for a moment and then release it.
  - ⊙ Result: The motion alarm should sound when the control handle is moved of center in either direction.
- 16 Press and hold the drive/steer function enable switch on the control handle. Press and hold the thumb rocker switch for a moment to the left position and then release it. Press and hold the thumb rocker switch for a moment to the right position and then release it.
  - ⊙ Result: The motion alarm should sound when the rocker switch is moved off center in either direction.

### Q-8

#### Inspect the Tires and Wheels (including castle nut torque)



Genie specifications require that this procedure be performed quarterly.

Maintaining the tires and wheels, including proper wheel fastener torque, is essential to safe operation and good performance. Tire and/or wheel failure could result in a machine tip-over. Component damage may also result if problems are not discovered and repaired in a timely fashion.

- 1 Check the tire surface and sidewalls for cuts, cracks, punctures and unusual wear.
- 2 Check each wheel for damage, bends and cracked welds.
- 3 Remove the cotter pin and check the castle nut for proper torque. Refer to Specifications, *Tire and Wheel Specifications*.

Note: Always replace the cotter pin with a new one when removing the castle nut or when checking the torque of the castle nut.

- 4 Install a new cotter pin. Bend the cotter pin to lock it in place.

## Quarterly Maintenance Procedures

### Q-9 Check the Lifting Chain Adjustments

Genie specifications require that this procedure be performed quarterly.

Maintaining proper adjustment of the lifting chains is essential to safe machine operation. Failure to maintain proper chain adjustment could result in an unsafe operating condition and may cause component damage.

- 1 Fully lower the platform and measure the maximum height of the machine.
- 2 Result: The machine is within specification. No adjustment required. Refer to Specifications, *Machine Specifications*.
- 3 Result: The machine is not within specification. Adjust the chains. Refer to Repair Procedure, *How to Adjust the Lifting Chains*.

### Q-10 Clean and Lubricate the Columns



Genie specifications require that this procedure be performed quarterly.

Clean and properly lubricated columns are essential to good machine performance and safe operation. Extremely dirty conditions may require that the columns be cleaned and lubricated more often.

- 1 Raise the platform to the maximum height.
- 2 Place a lifting strap from an overhead crane under the platform. Support the platform. Do not apply any lifting pressure.

#### NOTICE

Component damage hazard. The platform railings can be damaged if they are used to lift the platform. Do not attach the lifting strap to the platform railings.

- 3 Visually inspect the inner and outer channels of the columns for debris or foreign material. If necessary, use a mild cleaning solvent to clean the columns.

#### CAUTION

Bodily injury hazard. This procedure will require the use of additional access equipment. Do not place ladders or scaffold on or against any part of the machine. Performing this procedure without the proper skills and tools could result in death or serious injury. Dealer service is strongly recommended.

- 4 If needed, apply a generous amount of Boelube® wax to the inside and outside channels of each column.

## Quarterly Maintenance Procedures

### Q-11 Adjust the Sequencing Cables



Genie specifications require that this procedure be performed quarterly.

Maintaining proper adjustment of the sequencing cables is essential for safe machine operation. An unsafe working condition exists if the sequencing cables are improperly adjusted. A frequent check allows the inspector to identify changes in the sequencing cables operating condition that might indicate damage.

- 1 Fully lower the platform.
- 2 Locate the compression spring on each sequencing cable.

Note: The spring is located between the nylock nut and the upper sequencing bracket.

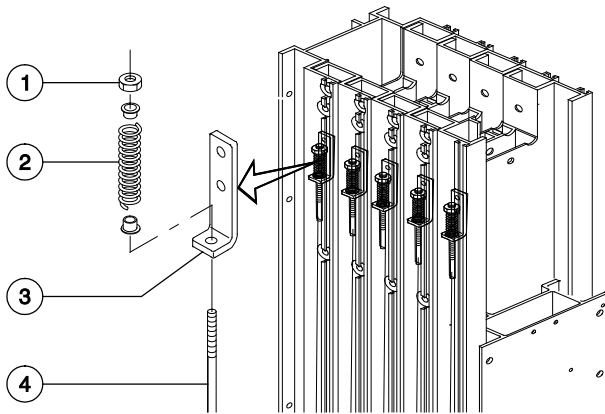

- 1 nylock nut
- 2 spring
- 3 upper sequencing bracket
- 4 sequencing cable

- 3 Confirm proper tension of each sequencing cable by measuring the height of the spring between the nylock nut and the upper sequencing bracket.
  - ⊙ Result: The measurement is within specification. Proceed to step 7.
  - ⊗ Result: The measurement is not within specification. Proceed to step 4.

#### Sequencing cable spring specification

Measurement, compressed	15/16 inch 2.4 cm
-------------------------	----------------------

- 4 Adjust the spring compressed length by turning the nylock nut clockwise to decrease the spring length or counterclockwise to increase the spring length.

**NOTICE** Component damage hazard. Do not compress the spring to less than specification.

- 5 Raise and lower the platform through three complete cycles.
- 6 Repeat this procedure beginning with step 3.
- 7 Repeat steps 3 through 5 for each sequencing cable as required.

## Quarterly Maintenance Procedures

### Q-12

### Visual Inspection of the Hydraulic Oil



Genie specifications require that this procedure be performed quarterly.

Replacement or testing of the hydraulic oil is essential for good machine performance and service life. Dirty oil and a clogged suction strainer may cause the machine to perform poorly and continued use may cause component damage. Extremely dirty conditions may require oil changes to be performed more often. For hydraulic oil specifications, Refer to Specifications, *Hydraulic Specifications*.

**Note:** Before replacing the hydraulic oil, the oil may be tested by an oil distributor for specific levels of contamination to verify that changing the oil is necessary. Replace the oil when it fails the test. Refer to Maintenance Procedure, *Test or Replace the Hydraulic Oil*.

- 1 Collect a sample of hydraulic oil and place in a clear container. Visually inspect the hydraulic oil for the following:
  - Color: oil should be a clear, light-honey colored
  - Appearance, oil should be clear and not cloudy or visibly distorts the view through the sight glass or container
  - Contains no particles, foreign objects, or other contamination
  - The hydraulic oil can be inspected by smell (can smell “hot” but not “burnt”) or rubbing between fingers (should feel viscous and free of any rough feel due to particles)
- ⦿ If the hydraulic oil passes all of the above inspections, continue the scheduled maintenance intervals.
- ⊗ If the hydraulic oil fails any of the above inspections, the hydraulic oil must be tested by an oil distributor or replaced.

**Note:** If the hydraulic oil was not replaced at or before the 2000 hour maintenance interval, the oil must be tested every quarter by an oil distributor until the oil fails the test and is replaced. After the oil has been replaced, continue the scheduled quarterly maintenance inspection.

**Note:** When replacing the hydraulic oil, it is recommended that all hydraulic filters be replaced at the same time.

## Quarterly Maintenance Procedures

### Q-13

#### Test the Drive Brakes

Genie specifications require that this procedure be performed quarterly.

Proper brake action is essential to safe machine operation. The drive brake function should operate smoothly, free of hesitation, jerking and unusual noise. Hydraulically-released individual wheel brakes can appear to operate normally when not fully operational.

Note: Perform this procedure with the machine on a firm, level surface that is free of obstructions.

Note: The platform extension deck must be fully retracted and the platform in the stowed position.

- 1 Mark a test line on the ground for reference.
- 2 Turn the key switch to platform control and pull out the red Emergency Stop button to the on position at both the ground and platform controls.
- 3 Lower the platform to the stowed position.
- 4 Choose a point on the machine; i.e., contact patch of a tire, as a visual reference for use when crossing the test line.
- 5 Press and hold the drive/steer function enable switch on the control handle.

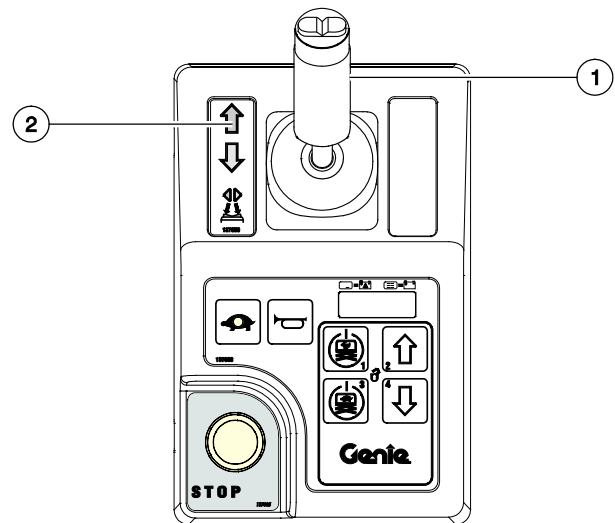

- 1 drive /steer function enable switch
  - 2 blue arrow
- 6 Move the control handle in the direction indicated by the blue arrow on the control panel until the machine begins to move forward.
  - 7 Bring the machine to top drive speed before reaching the test line. Release the drive/steer function enable switch or the joystick when your reference point on the machine crosses the test line.
  - 8 Measure the distance between the test line and your machine reference point. Refer Specifications, *Performance Specifications*.

Note: The brakes must be able to hold the machine on any slope it is able to climb.

## Quarterly Maintenance Procedures

### Q-14 Test the Drive Speed – Stowed Position

Genie specifications require that this procedure be performed quarterly.

Proper drive function is essential to safe machine operation. The drive function should respond quickly and smoothly to operator control. Drive performance should also be free of hesitation, jerking and unusual noise over the entire proportionally controlled speed range.

Note: Perform this procedure with the machine on a firm, level surface that is free of obstructions.

Note: Perform this procedure with the machine in the stowed position.

- 1 Create start and finish lines by marking two lines on the ground 40 feet / 12.2 m apart.
  - 2 Choose a point on the machine (i.e., contact patch of a tire) as a visual reference for use when crossing the start and finish lines.
- Note: Be sure the low drive speed light is off. If the low drive speed light is on, press the drive speed select button to turn off the low drive speed function.
- 3 Press and hold the drive/steer function enable switch on the control handle.

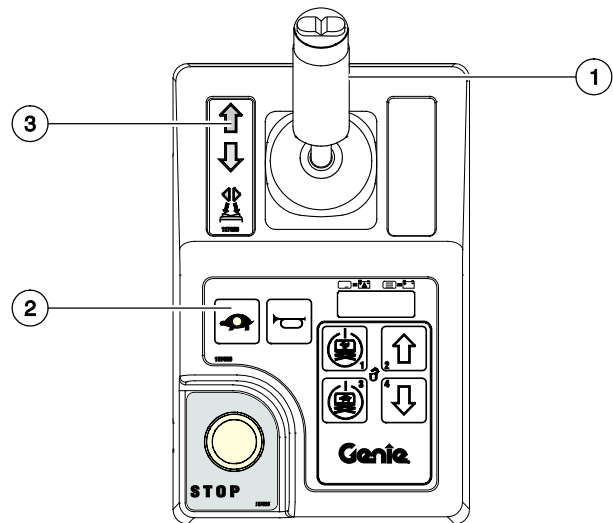

- 1 drive/steer function enable switch
  - 2 slow drive speed button
  - 3 blue arrow
- 4 Move the control handle in the direction indicated by the blue arrow on the control panel until the machine begins to move forward.
  - 5 Bring the machine to top drive speed before reaching the start line. Begin timing when your reference point on the machine crosses the start line.
  - 6 Continue at full speed and note the time when the machine reference point crosses the finish line. Refer to Specifications, *Performance Specifications*.

## Quarterly Maintenance Procedures

### Q-15 Test the Drive Speed - Raised Position



Genie specifications require that this procedure be performed quarterly.

Proper drive function is essential to safe machine operation. The drive function should respond quickly and smoothly to operator control. Drive performance should also be free of hesitation, jerking and unusual noise over the entire proportionally controlled speed range.

**Note:** Perform this procedure with the machine on a firm, level surface that is free of obstructions.

- 1 Create start and finish lines by marking two lines on the ground 40 feet / 12.2 m apart.
- 2 Press and hold the high or low speed lift enable button.
- 3 Press the platform up button.
- 4 Raise the platform approximately 4 feet / 1.2 m from the ground.
- 5 Choose a point on the machine (i.e., contact patch of a tire) as a visual reference for use when crossing the start and finish lines.
- 6 Press and hold the drive/steer function enable switch on the control handle.
- 7 Move the control handle in the direction indicated by the blue arrow on the control panel until the machine begins to move forward.
- 8 Bring the machine to top drive speed before reaching the start line. Begin timing when your reference point on the machine crosses the start line.
- 9 Continue at full speed and note the time when the machine reference point crosses the finish line. Refer to Specifications, *Performance Specifications*.

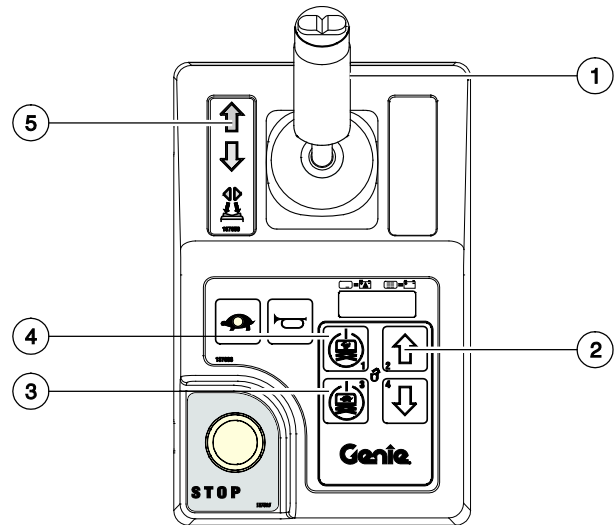

- 1 drive /steer function enable switch
- 2 platform up button
- 3 low speed lift enable
- 4 high speed lift enable
- 5 blue arrow

## Annual Maintenance Procedures

### A-1 Grease the Platform Overload Mechanism (if equipped)



Genie specifications require that this procedure be performed annually.

Perform this procedure more often if dusty conditions exist.

Application of lubrication to the platform overload mechanism is essential to safe machine operation. Continued use of an improperly greased platform overload mechanism could result in the system not sensing an overloaded platform condition and will result in component damage.

- 1 Locate the grease fittings on each pivot pin of the platform overload assembly.
- 2 Thoroughly pump grease into each grease fitting.

---

#### Grease Specification

---

Chevron Ultra-duty grease, EP NLGI 1 (lithium based) or equivalent

---

### A-2 Test the Platform Overload System (if equipped)



Genie specifications require that this procedure be performed annually OR when the machine fails to lift the maximum rated load.

Testing the platform overload system regularly is essential to safe machine operation. Continued use of an improperly operating platform overload system could result in the system not sensing an overloaded platform condition. Machine stability could be compromised resulting in the machine tipping over.

Note: Perform this procedure with the machine on a firm, level surface.

- 1 Turn the key switch to platform control and pull out the red Emergency Stop button to the on position at both the ground and platform controls.
- 2 Determine the maximum platform capacity. Refer to the machine serial plate.

## Annual Maintenance Procedures

- 3 Using a suitable lifting device, place a test weight equal to that of the available capacity in one of the locations shown. Refer to Illustration 1.
- ⦿ Result: The LCD at the ground controls should display READY, the machine model and machine hours, indicating a normal condition. The LED readout on the platform controls should display CH. Refer to the examples below.

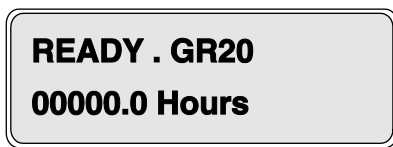

GCON LCD

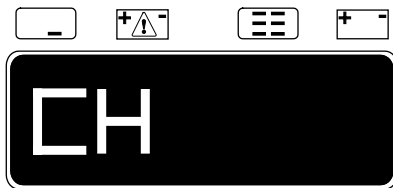

PCON LCD

- ⊗ Result: The LCD at the ground controls displays OL: Platform Overloaded and the LED readout on the platform controls displays a flashing OL. The platform overload system is not operating properly. Refer to Repair Procedure, *Calibrate the Platform Overload System* (if equipped).



GCON LCD

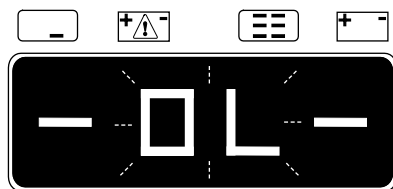

PCON LCD

- 4 Add additional weight to the platform that is equal to, but does not exceed 15% of the maximum rated load. Secure the additional weight. Refer to the machine serial plate.
- ⦿ Result: The LCD at the ground controls displays OL: Platform Overloaded and the LED readout on the platform controls displays a flashing OL. The platform overload system is operating properly
- ⊗ Result: The LCD at the ground controls displays READY, the machine model and machine hours. The LED readout on the platform controls displays CH. The platform overload system is not operating properly. Refer to Repair Procedure, *Calibrate the Platform Overload System* (if equipped).
- 5 Test all machine functions from the platform controls.
- ⦿ Result: All platform control functions should not operate.
- 6 Turn the key switch to ground controls.
- 7 Test all machine functions from the ground controls.
- ⦿ Result: All ground control functions should not operate.
- 8 Lift the test weight off the platform floor using a suitable lifting device. Turn the key switch to the off position.

---

## Annual Maintenance Procedures

- 9 Turn the key switch to ground controls.
  - ⦿ Result: The LCD at the ground controls displays READY, the machine model and machine hours. The LED readout on the platform controls displays CH. The platform overload system is operating properly
  - ⊗ Result: The LCD at the ground controls displays OL: Platform Overloaded and the LED readout on the platform controls displays a flashing OL. The platform overload system is not operating properly. Refer to Repair Procedure, *Calibrate the Platform Overload System* (if equipped).
- 10 Test all machine functions from the ground controls.
  - ⦿ Result: All ground control functions should operate normally.
- 11 Turn the key switch to platform controls.
- 12 Test all machine functions from the platform controls.
- 13 Result: All platform control functions should operate normally.

## Programmed Maintenance Procedures

### P0-1

#### Grease the Steer Yokes



Genie specifications require that this procedure be performed every 100 hours of operation.

Regular application of lubrication to the steer yokes is essential to good machine performance and service life. Continued use of an insufficiently greased steer yoke will result in component damage.

- 1 Locate the grease fitting on the top of the steer yoke.
- 2 Pump multipurpose grease into the steer yoke until the steer yoke is full and grease is being forced past the bearings. Repeat this step for the other steer yoke.

---

#### Grease Specifications

---

Chevron Ultra-duty grease, EP NLGI 2 (lithium based) or equivalent

---

### P1-1

#### Inspect the Mast Assembly for Wear



Genie specifications require that this procedure be performed every 1000 hours of operation.

Detection of excessive or unusual wear in the mast assembly is essential for safe machine operation. An unsafe working condition exists if the mast assembly has excessive wear and/or does not operate smoothly, free of hesitation and binding.

- 1 Remove the mast covers.

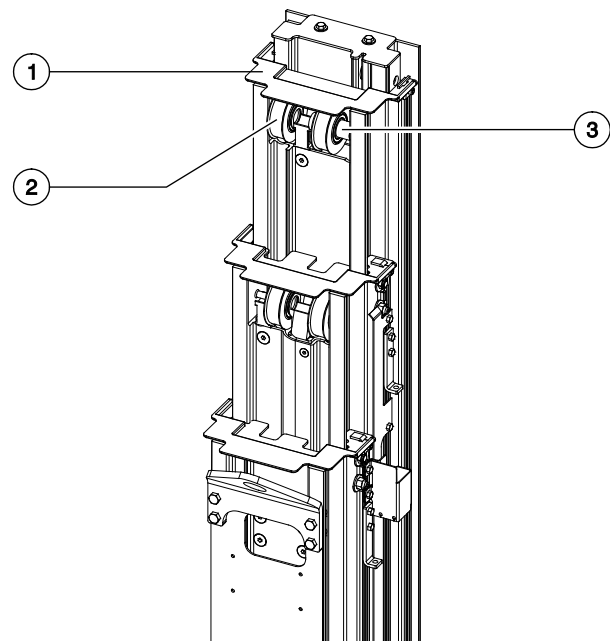

GR-15 shown

- 1 mast cover
- 2 idler wheel
- 3 spacer

## Programmed Maintenance Procedures

- 2 Raise the platform until approximately 4 inches / 10 cm of each column is visible.
- 3 **GR-12, GR-15, QS-12R, QS-15R, QS-12W, QS-15W:** Visually inspect the top of each column for clearance between the roller wheels and the adjacent column surface.  
**GR-20, QS-20R, QS-20W:** Visually inspect the top of each column for clearance between the slider block and the adjacent column surface.
- ⦿ **Result:** There should be an equal amount of distance between the roller wheel/slider block and the column on each side.

Note: If most inspection results in a measurement that is not within specification, refer to Repair Procedure, *How to Adjust the Glide Pads*.

- 4 Loosen but do not remove the adjustment nut on the sequencing cable located at the top of the first column.
- 5 Raise the platform approximately 3 feet / 1 m above the top of the drive chassis.
- 6 Place a jack stand on the top of the battery cover, centered under the platform. Adjust the jack stand height to 24 inches / 60 cm.
- 7 Lower the platform onto the jack stand just enough to take the weight off the lifting chains.

### **⚠ WARNING**

Crushing hazard. Keep hands clear of the jack stand when lowering the platform.

## P1-2

### Inspect and Lubricate the Lifting Chains



Genie specifications require that this procedure be performed every 1000 hours of operation.

Lubricated chains are essential to good machine performance and safe operation. Extremely dirty conditions may require that the chains be cleaned and lubricated more often.

- 1 Thoroughly inspect the lifting chains. Refer to Repair Procedure, *How to Inspect the Lifting Chains*.
- 2 Raise the platform to the maximum height.
- 3 Place a lifting strap from an overhead crane under the platform. Support the platform. Do not apply lifting pressure.

### **NOTICE**

Component damage hazard. The platform railings can be damaged if they are used to lift the platform. Do not attach the lifting strap to the platform railings.

- 4 Lubricate each chain with a dry silicon spray lubricant.

### **⚠ WARNING**

Bodily injury hazard. This procedure will require the use of additional access equipment. Do not place ladders or scaffolding on or against any part of the machine. Performing this procedure without the proper skills and tools could result in death or serious injury. Dealer service is strongly recommended.

## Programmed Maintenance Procedures

### P2-1 Replace the Hydraulic Return Filter



Genie specifications require that this procedure be performed every 1000 hours of operation.

Replacement of the hydraulic tank return filter is essential for good machine performance and service life. A dirty or clogged filter may cause the machine to perform poorly and continued use may cause component damage. Extremely dirty conditions may require that the filter be replaced more often.

**CAUTION** Beware of hot oil. Contact with hot oil may cause severe burns.

Note: The hydraulic tank return filter is mounted next to the hydraulic tank.

- 1 Clean the area around the oil filter. Remove the filter with an oil filter wrench.
- 2 Apply a thin layer of fresh oil to the gasket of the new oil filter.
- 3 Install the new filter and tighten it securely by hand.
- 4 Use a permanent ink marker to write the date and number of hours from the hour meter on the oil filter.
- 5 Raise the platform approximately 3 feet / 1 m.
- 6 Inspect the filter and related components for leaks.
- 7 Clean up and properly dispose of any oil that may have spilled during the installation procedure.

### P2-2 Test or Replace the Hydraulic Oil



Genie requires that this procedure be performed every 2000 hours.

Replacement or testing of the hydraulic oil is essential for good machine performance and service life. Dirty oil and a clogged suction strainer or hydraulic filters may cause the machine to perform poorly and continued use may cause component damage. Extremely dirty conditions may require oil changes to be performed more frequently.

Note: Before replacing the hydraulic oil, the oil may be tested by an oil distributor for specific levels of contamination to verify that changing the oil is necessary. If the hydraulic oil is not replaced at the 2000 hour inspection, test the oil quarterly. Replace the oil when it fails the test.

Note: When removing a hose assembly or fitting, the O-ring (if equipped) on the fitting and/or hose end must be replaced. All connections must be torqued to specification during installation. Refer to Specifications, *Hydraulic Hose and Fitting Torque Specifications*.

Note: Perform this procedure with the platform in the stowed position.

## Programmed Maintenance Procedures

### Testing the oil:

- 1 Complete the hydraulic oil testing with an oil distributor.
- ⊙ If the hydraulic oil passes testing at the 2000 hour maintenance interval, the oil must be tested every quarter by an oil distributor until the oil fails the test and is replaced.
- ⊗ If the hydraulic oil fails testing at the 2000 hour maintenance interval, the oil must be replaced. After the oil has been replaced, continue the scheduled quarterly maintenance inspection.

### Replacing the hydraulic oil:

- 1 Tag and disconnect the hydraulic tank return hard line from the hydraulic filter head and remove the hard line from the tank. Cap the fitting on the filter head.

#### **WARNING**

Bodily injury hazard. Spraying hydraulic oil can penetrate and burn skin. Loosen hydraulic connections very slowly to allow the oil pressure to dissipate gradually. Do not allow oil to squirt or spray.

- 2 Tag and disconnect the hydraulic pump inlet hard line and remove the hard line from the tank. Cap the fitting on the pump.
- 3 Remove the hydraulic tank retaining fasteners and remove the hydraulic tank from the machine.
- 4 Drain all of the oil into a suitable container. Refer to Machine Specifications, for capacity information.

Note: When replacing the hydraulic oil, it is recommended that the hydraulic tank be cleaned using a mild solvent and all hydraulic filters and strainers be replaced.

- 5 Clean up any oil that may have spilled. Properly discard the used oil.
- 6 Clean the inside of the hydraulic tank using a mild solvent. Allow the tank to dry completely.

- 7 Install the hydraulic tank and install and tighten the hydraulic tank retaining fasteners. Torque to specification.

#### Torque specifications

Hydraulic tank retaining fasteners, dry	35 in-lbs 4 Nm
Hydraulic tank retaining fasteners, lubricated	26 in-lbs 2.9 Nm

- 8 Install the hydraulic pump inlet hard line into the tank. Install the fitting onto the pump and torque to specification. Refer to Specifications, *Hydraulic Hose and Fitting Torque Specifications*.
- 9 Install the hydraulic pump return hard line into the tank. Install the fitting onto the hydraulic filter head and torque to specification. Refer to Specifications, *Hydraulic Hose and Fitting Torque Specifications*.
- 10 Fill the tank with the proper hydraulic oil for your machine. Refer to Specifications, *Hydraulic Specifications*.
- 11 Activate the pump to fill the hydraulic system with oil and bleed the system of air.

#### **NOTICE**

Component damage hazard. The pump can be damaged if operated without oil. Be careful not to empty the hydraulic tank while in the process of filling the hydraulic system. Do not allow the pump to cavitate.

- 12 Repeat steps 12 and 13 until the hydraulic system and tank are both full.

Note: After the oil has been replaced, continue the scheduled quarterly maintenance inspection.

## Repair Procedures



### Observe and Obey:

- Repair procedures shall be completed by a person trained and qualified on the repair of this machine.
- Immediately tag and remove from service a damaged or malfunctioning machine.
- Repair any machine damage or malfunction before operating the machine.

### Before Repairs Start:

- Read, understand and obey the safety rules and operating instructions in the appropriate operator's manual on your machine.
- Be sure that all necessary tools and parts are available and ready for use.
- Use only Genie approved replacement parts.
- Read each procedure completely and adhere to the instructions. Attempting shortcuts may produce hazardous conditions.

### Machine Configuration:

- Unless otherwise specified, perform each repair procedure with the machine in the following configuration:
  - Machine parked on a firm, level surface
  - Key switch in the off position with the key removed
  - The red Emergency Stop button in the off position at both the ground and platform controls
  - Wheels chocked
  - All external AC power supply disconnected from the machine
  - Platform in the stowed position

# Repair Procedures

## About This Section

Most of the procedures in this section should only be performed by trained service professional in a suitably equipped workshop. Select the appropriate repair procedure after troubleshooting the problem.

Perform disassembly procedures to the point where repairs can be completed. Then to re-assemble, perform the disassembly steps in reverse order.

## Symbols Legend



Safety alert symbol—used to alert personnel to potential personal injury hazards. Obey all safety messages that follow this symbol to avoid possible injury or death.



Indicates a imminently hazardous situation which, if not avoided, will result in death or serious injury.



Indicates a potentially hazardous situation which, if not avoided, could result in death or serious injury.



Indicates a potentially hazardous situation which, if not avoided, may cause minor or moderate injury.



Indicates a potentially hazardous situation which, if not avoided, may result in property damage.

- ⦿ Indicates that a specific result is expected after performing a series of steps.
- ⊗ Indicates that an incorrect result has occurred after performing a series of steps.

## Platform Controls

The platform controls are used to operate the machine from the platform.

Activating a function button sends a signal to the Electronic Control Module (ECM). When the ECM is in the function mode, the platform controls are used to operate the various machine functions.

The platform controls consist of an Emergency Stop button, electronic circuit board, proportional control handle, drive/steer enable switch, alarm, function buttons and LED display.

For further information or assistance, contact Genie Product Support.

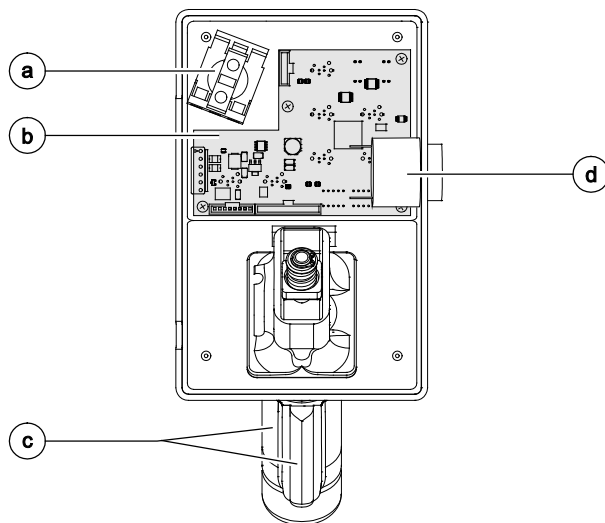

- a red Emergency Stop button P2
- b platform controls circuit board U3
- c proportional control handle and drive/steer enable switch JC9
- d alarm H1

## Platform Controls

### Operational Indicator Codes

These codes are generated by the electrical system to indicate machine operating status. During normal operation, a code will appear in the platform controls LED readout if a condition such as off-level, overload cutout, chassis mode operation or pothole guard stuck occurs.

If the platform controls LED readout displays an operational indicator code such as LL, the fault condition must be repaired or removed before resuming machine operation. Push in and pull out the red Emergency Stop button to reset the system.

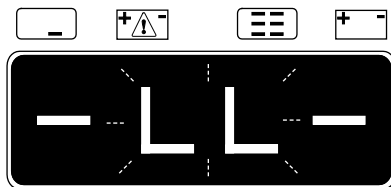

Platform Controls LED Readout

Code	Condition
LL	Off-level
OL	Platform Overload (CE and Australia)
CH	Chassis Mode Operation
PHS	Pothole Guard Stuck
OAC	Obstruction Detected (QS models)

Note: The **Ld** Operation Indicator Code will appear when the outriggers are not fully retracted, the machine is not auto leveled, an outrigger has lost contact with the ground or either level sensor detects the machine is no longer level. When any of the above scenarios occur, the lift function is disabled.

The lift function will also be disabled while extending or retracting the outriggers and during the outrigger auto level procedure. While performing the above operations, the **Ld** Operation Indicator Code will appear.

Note: A code and a description of a code can also be viewed at the ground controls LCD display.

## Platform Controls

### 1-1 Circuit Board

---

#### How to Remove the Platform Controls Circuit Board

- 1 Push in the red Emergency Stop button to the off position at both the ground and platform controls.
- 2 Disconnect the platform controls from the control cable at the platform.
- 3 Remove the fasteners securing the platform control box to the platform control bracket.
- 4 Remove the fasteners securing the bottom cover to the platform control box. Open the control box.
- 5 Remove the ties securing the wire harness.
- 6 Disconnect the red and black wires from the alarm.
- 7 Carefully remove the alarm from the platform control box.

- 8 Carefully disconnect all wire harness connectors from the platform controls circuit board.

#### **▲ WARNING**

Electrocution/burn hazard. Contact with electrically charged circuits could result in death or serious injury. Remove all rings, watches and other jewelry.

#### **NOTICE**

Component damage hazard. Electrostatic discharge (ESD) can damage printed circuit board components. Maintain firm contact with a metal part of the machine that is grounded at all times when handling printed circuit boards OR use a grounded wrist strap.

- 9 Carefully remove the platform controls circuit board fasteners.
- 10 Carefully remove the platform controls circuit board from the platform control box.
- 11 Remove the transparent caps from the platform controls circuit board and save.

---

#### **Circuit board fastener torque specifications**

Hand tighten until screws seat	< 5 in-lbs < 0.6 Nm
--------------------------------	------------------------

Note: Before installing a circuit board, place the transparent caps removed in step 11, over the circuit board buttons.

Note: After installing the circuit board, check for proper button operation. Excessive torque of the circuit board fasteners will cause the buttons to bind. Moderate torque of the circuit board fasteners will not allow the buttons to engage.

## Platform Controls

### 1-2 Joystick

#### How to Remove the Joystick

- 1 Push in the red Emergency Stop button to the off position at both the ground and platform controls.
- 2 Disconnect the platform controls from the control cable at the platform.
- 3 Remove the fasteners securing the platform control box to the platform control bracket.
- 4 Remove the fasteners securing the bottom cover to the platform control box. Open the control box.
- 5 Remove the ties securing the joystick wire harness.
- 6 Carefully disconnect the joystick wire harness from the platform controls circuit board.

**⚠ WARNING** Electrocution/burn hazard. Contact with electrically charged circuits could result in death or serious injury. Remove all rings, watches and other jewelry.

**NOTICE** Component damage hazard. Electrostatic discharge (ESD) can damage printed circuit board components. Maintain firm contact with a metal part of the machine that is grounded at all times when handling printed circuit boards OR use a grounded wrist strap.

- 7 Carefully remove the joystick fasteners.
- 8 Carefully remove the joystick from the platform control box.

#### Torque specifications

Joystick fasteners	9 in-lbs 1 Nm
--------------------	------------------

### 1-3 Platform Controls Alarm

#### How to Remove the Platform Controls Alarm

- 1 Push in the red Emergency Stop button to the off position at both the ground and platform controls.
- 2 Disconnect the platform controls from the control cable at the platform.
- 3 Remove the fasteners securing the platform control box to the platform control bracket.
- 4 Remove the fasteners securing the bottom cover to the platform control box. Open the control box.
- 5 Disconnect the red and black wires from the alarm.

**⚠ WARNING** Electrocution/burn hazard. Contact with electrically charged circuits could result in death or serious injury. Remove all rings, watches and other jewelry.

**NOTICE** Component damage hazard. Electrostatic discharge (ESD) can damage printed circuit board components. Maintain firm contact with a metal part of the machine that is grounded at all times when handling printed circuit boards OR use a grounded wrist strap.

- 6 Carefully remove the alarm from the platform control box.

## Platform Controls

### 1-4 Platform Emergency Stop Button

#### How to Remove the Platform Controls Emergency Stop Button

- 1 Push in the red Emergency Stop button to the off position at both the ground and platform controls.
- 2 Disconnect the platform controls from the control cable at the platform.
- 3 Remove the fasteners securing the platform control box to the platform control bracket.
- 4 Remove the fasteners securing the bottom cover to the platform control box. Open the control box.

- 5 Disconnect the white wires from the Emergency Stop base.

**⚠ WARNING**

Electrocution/burn hazard. Contact with electrically charged circuits could result in death or serious injury. Remove all rings, watches and other jewelry.

**NOTICE**

Component damage hazard. Electrostatic discharge (ESD) can damage printed circuit board components. Maintain firm contact with a metal part of the machine that is grounded at all times when handling printed circuit boards OR use a grounded wrist strap.

- 6 Carefully remove the Emergency Stop base from the Emergency Stop button.
- 7 Carefully remove the retaining ring from the Emergency Stop button.
- 8 Carefully remove the Emergency Stop button from the platform control box.

## Ground Controls

The ground controls, used to operate the machine from the ground, can also be used to tune the performance of the machine.

The ground controls consist of an Electronic Control Module (ECM), emergency stop button, key switch and circuit breaker.

Activating the function enable button and the up or down at the same time, sends a signal to the (ECM). This allows the platform to be raised or lowered at the ground controls.

Note: Steer and drive functions are not available at the ground controls.

When the ECM is in the set up mode, the ground controls are used to adjust the function speed parameters, machine models, or machine options.

For further information or assistance, contact Genie Product Support.

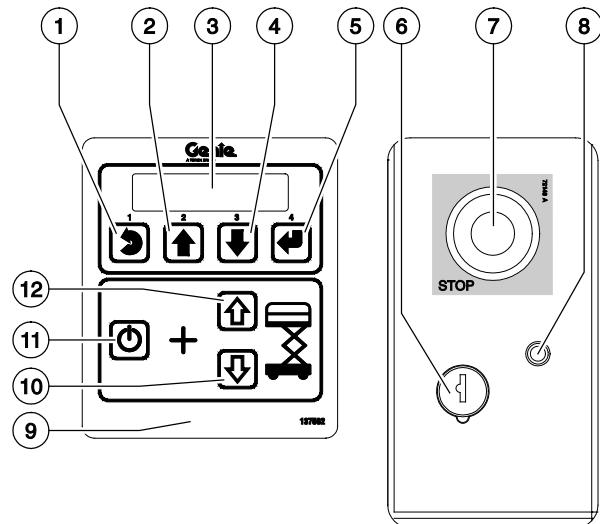

- 1 machine setup escape button
- 2 machine setup scroll up button
- 3 LCD readout
- 4 machine setup scroll down button
- 5 machine setup enter button
- 6 Key switch KS1
- 7 red Emergency Stop P1
- 8 circuit breaker CB2
- 9 ECM U5
- 10 platform down button
- 11 lift function enable button
- 12 platform up button

## Ground Controls

### 2-1 Software Revision Level

#### How to Determine the Software Revision Level

The machine software revision level is displayed at the ground controls LCD display.

- 1 Turn the key switch to the ground controls or platform controls position. Pull out the red Emergency Stop button to the on position at both ground and platform controls.
- ⦿ Result: The display at the platform controls will show "CH". See example below.

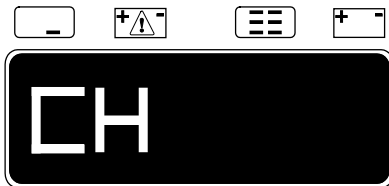

- ⦿ Result: The display at the ground controls will show the machine model and hour meter information. After 3 seconds, the machine model will not show on the display. See example below.

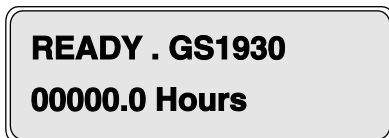

- 2 Press the ground control scroll down button.
- ⦿ Result: The ground control LCD display will indicate the software revision and hour meter information. After 5 seconds, the ground controls LCD display will display machine model and hour meter information again. See example below.
- 3 Push in the red Emergency Stop button to the off position at both the ground and platform controls and turn the key switch to the off position.

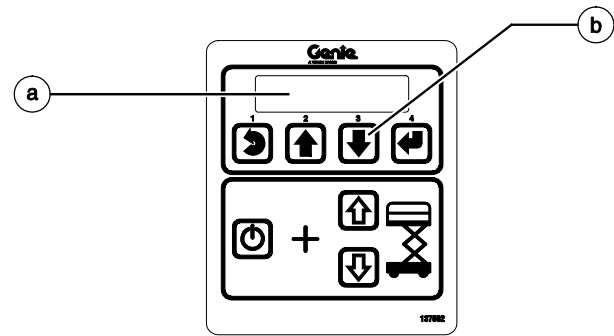

- a ground control LCD display  
b ground control scroll down button

# Ground Controls

## 2-2 Machine Setup

### How to Setup the Machine from Ground Controls

The ground controls can be used to setup the machine parameters from the ground. Features that can be adjusted from the ground controls include machine Model, Options and Speed setup. This menu can only be entered from ground controls with the key switch in the ground controls position.

**⚠ DANGER** Tip-over hazard. Do not adjust function speeds higher than specified in this procedure. Setting the function speeds greater than specifications could cause the machine to tip over resulting in death or serious injury.

**⚠ DANGER** Tip-over hazard. This procedure must only be performed by a trained service professional. Attempting this procedure without the necessary skills could result in death or serious injury.

Note: Select a test area that is firm, level and free of obstructions.

1 Turn the key switch to ground controls.

2 Press and hold the ground control scroll up and scroll down buttons.

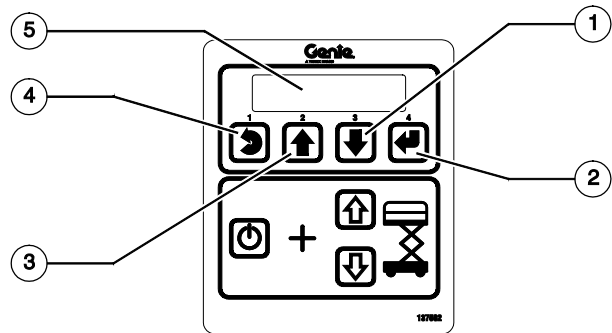

Ground Control Menu Buttons

- 1 scroll down button
- 2 enter button
- 3 scroll up button
- 4 escape button
- 5 LCD display

3 Pull out the red Emergency Stop button to the on position at the ground controls.

⦿ Result: The ground controls LCD display will show the following:



4 Use the ground control menu buttons to select machine Model, Options and Speed Setup parameters. Follow the menu structure indicated on the ground control LCD display.

# Ground Controls

## 2-3 Level Sensors

The Electronic Control Module (ECM) is programmed to deactivate the lift and drive functions and activate an alarm when a signal is received from the level sensor.

The tilt alarm sounds when the incline of the chassis exceeds 1.5° to the side and 3° to the front or rear.

Use the illustrations to verify which type of level sensor is installed and perform the procedure that is appropriate for your machine.

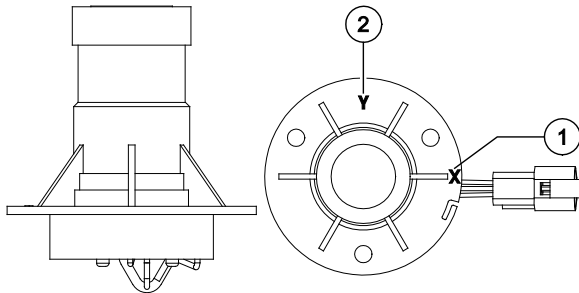

Procedure 1

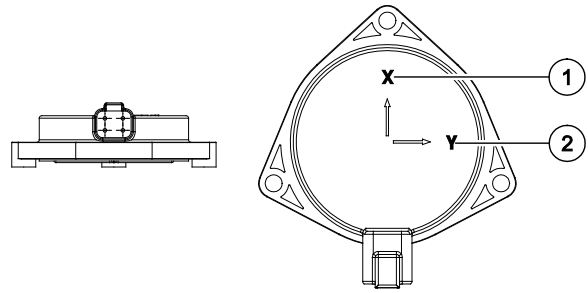

Procedure 2

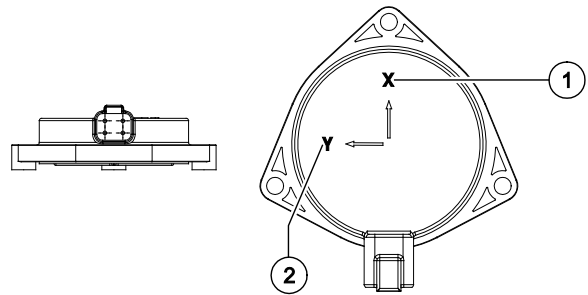

Procedure 2

- 1 X axis
- 2 Y axis

## Ground Controls

### How to Install and Calibrate the Level Sensor - Procedure 1

**⚠ DANGER** Tip-over hazard. Failure to install or calibrate the level sensor as instructed will compromise machine stability and cause the machine to tip over, resulting in death or serious injury. Do not install or calibrate the level sensor other than specified in this procedure.

- 1 Move the machine to an area that has a firm, level surface and is free of obstructions.

Note: The surface must be  $0^\circ \pm 0.5^\circ$ .

Note: If you are not installing a new level sensor, proceed to step 7.

- 2 Tag and disconnect the level sensor wire harness from the chassis wire harness.
- 3 Remove the level sensor adjusting fasteners. Remove the level sensor from the machine.

- 4 Place the level sensor onto the level sensor base with the "X" on the level sensor closest to the mast of the machine and the "Y" on the level sensor closest to the steer end of the machine.

**⚠ DANGER** Tip-over hazard. The level sensor must be installed with the "X" on the level sensor base closest to the mast of the machine. Failure to install the level sensor as instructed could result in the machine tipping over causing death or serious injury.

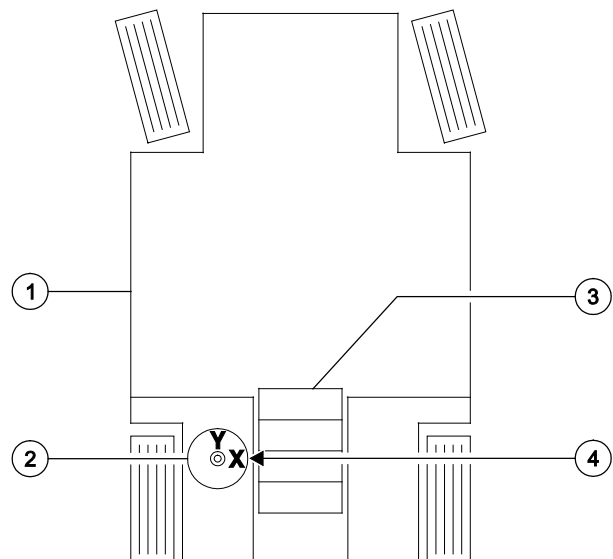

- 1 drive chassis
- 2 level sensor
- 3 X axis
- 4 mast

## Ground Controls

- 5 Install the level sensor retaining fasteners through the level sensor and springs, and into the mount bracket. Tighten the fasteners and measure the distance between the level sensor and the level sensor mount bracket.
  - ⦿ Result: The measurement should be approximately 0.375 inch / 10 mm.
- 6 Connect the chassis wire harness to the level sensor wire harness.
- 7 Adjust the level sensor retaining fasteners until the bubble at the top of the level sensor is centered in the circles.

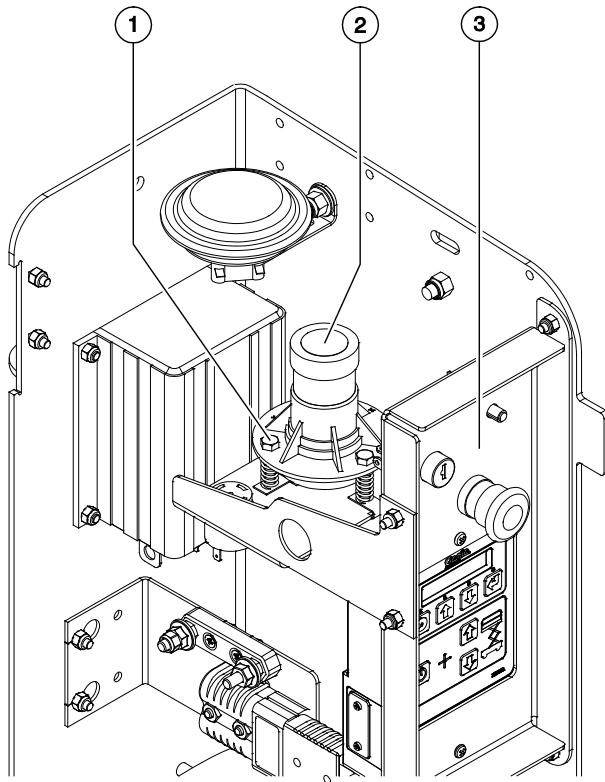

- 1 adjustment fastener
- 2 calibration circle
- 3 ground controls

- 8 Turn the key switch to the ground control and pull out the red Emergency Stop button to the on position at the ground controls.
  - ⦿ Result: The tilt sensor alarm should not sound.
- 9 Center a lifting jack under the drive chassis at the ground controls side of the machine.
- 10 Raise the machine approximately 2 inches / 5 cm. Place blocks under both wheels.
  - GR-12, GR-15, QS-12R, QS-15R, QS-12W, QS-15W:** Place a 0.65 x 6 x 6 inch / 1.65 x 15 x 15 cm thick steel block under both wheels at the ground controls side of the machine.
  - GR-20, QS-20R, QS-20W:** Place a 0.7 x 6 x 6 inch / 1.78 x 15 x 15 cm thick steel block under both wheels at the ground controls side of the machine.
- 11 Lower the machine onto the blocks.
- 12 Raise the platform to approximately 1 ft / 30 cm.
  - ⦿ Result: The level sensor alarm should not sound.
  - ⊗ Result: The level sensor alarm does sound and fault code LL appears in the diagnostic display. Adjust the level sensor retaining fasteners just until the level sensor alarm does not sound.
- 13 Lower the platform to the stowed position.
- 14 Raise the machine approximately 2 inches / 5 cm. Remove the blocks from under both wheels..
- 15 Center a lifting jack under the drive chassis at the hydraulic tank side of the machine.

## Ground Controls

- 16 Raise the machine approximately 2 inches / 5 cm. Place blocks under both wheels.
- GR-12, GR-15, QS-12R, QS-15R, QS-12W, QS-15W:** Place a 0.79 x 6 x 6 inch / 2 x 15 x 15 cm thick steel block under both wheels at the hydraulic side of the machine.
- GR-20, QS-20R, QS-20W:** Place a 0.85 x 6 x 6 inch / 2.16 x 15 x 15 cm thick steel block under both wheels at the hydraulic tank side of the machine.
- 17 Lower the machine onto the blocks.
- 18 Raise the platform to approximately 1 ft / 30 cm.
- ⦿ Result: The platform should stop, an alarm should sound and fault code LL appears in the diagnostic display.
  - ⊗ Result: The platform does not stop or the level sensor alarm does not sound. Adjust the level sensor until the alarm just begins to sound OR the down limit switch may need to be adjusted.
- 19 Lower the platform to the stowed position.
- 20 Raise the machine approximately 2 inches / 5 cm. Remove the blocks from under both wheels..
- 21 Lower the machine and remove the jack.
- 22 Center a lifting jack under the drive chassis at the steer end of the machine.
- 23 Raise the machine approximately 2 inches / 5 cm.
- 24 Place a 2.18 x 6 x 6 inch / 5.54 x 15 x 15 cm thick steel block under both wheels at the steer end of the machine.
- 25 Lower the machine onto the blocks.
- 26 Raise the platform to approximately 1 ft / 30 cm.
- ⦿ Result: The level sensor alarm should not sound.
  - ⊗ Result: The level sensor alarm does sound. The level sensor is faulty and must be replaced. Repeat this procedure beginning with step 1.
- 27 Raise the machine approximately 2 inches / 5 cm. Remove the blocks from under both wheels..
- 28 Lower the machine and remove the jack.
- 29 Center a lifting jack under the drive chassis at the non-steer end of the machine.
- 30 Raise the machine approximately 2 inches / 5 cm.
- 31 Place a 2.4 x 6 x 6 inch / 6.1 x 15 x 15 cm thick steel block under both wheels at the non-steer end of the machine.
- 32 Raise the platform to approximately 1 ft / 30 cm.
- ⦿ Result: The platform should stop, an alarm should sound and fault code LL appears in the diagnostic display.
  - ⊗ Result: The platform does not stop or the level sensor alarm does not sound. The level sensor is faulty and must be replaced. Repeat this procedure beginning with step 1.
- 33 Lower the platform to the stowed position.
- 34 Raise the machine approximately 2 inches / 5 cm. Remove the blocks from under both wheels..
- 35 Lower the machine and remove the jack.

## Ground Controls

### How to Install and Calibrate the Level Sensor - Procedure 2

**⚠ DANGER** Tip-over hazard. Failure to install the level sensor as instructed will compromise machine stability and cause the machine to tip over, resulting in death or serious injury. Do not install the level sensor other than specified in this procedure.

Note: If you are **not** installing a new level sensor, proceed to step 8.

- 1 Move the machine to an area that has a firm, level surface and is free of obstructions.

Note: The surface must be  $0^\circ \pm 0.5^\circ$ .

- 2 Tag and disconnect the level sensor wire harness from the chassis wire harness.
- 3 Remove the level sensor retaining fasteners and remove the level sensor from the machine.

- 4 Place the new level sensor on to the level sensor bracket with the "X" on the level sensor towards the steer end of the machine.

**⚠ DANGER** Tip-over hazard. Failure to install the level sensor as instructed, could result in the machine tipping over, causing death or serious injury.

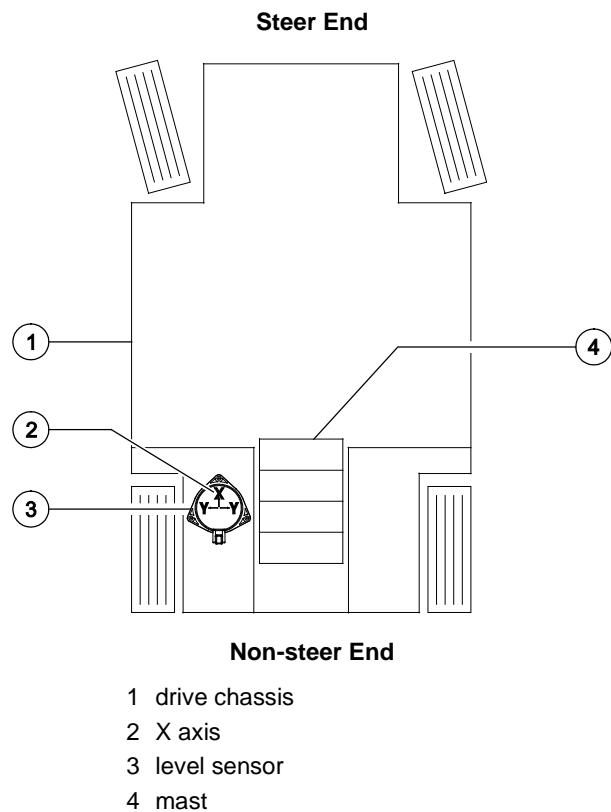

# Ground Controls

- 5 Install the level sensor retaining fasteners through the level sensor and springs. Secure the level sensor assembly to the machine.
- 6 Connect the chassis wire harness to the level sensor.
- 7 Turn the key switch to ground control and pull out the red Emergency Stop button to the on position at both ground and platform controls.
- ⦿ Result: GCON will display a 'C051: SYSTEMFAULT, TILT:NoCal fault.
- 8 Push in the red Emergency Stop button to the off position at the ground controls.
- 9 Press and hold the ground control scroll up and scroll down buttons.

- 10 Pull out the red Emergency Stop button to the on position at the ground controls.
- ⦿ Result: The ground controls LCD display will show the following:

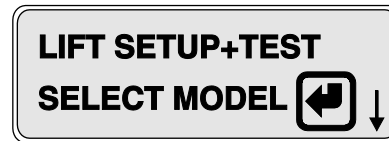

- 11 Release the Scroll Up and Scroll Down buttons after the ground controller powers up.
- 12 Use the Scroll Up or Scroll Down buttons to scroll to **Select Option**.



- 13 Press the Enter button.
- 14 Use the Scroll Up or Scroll Down buttons to scroll to Tilt Sensor.

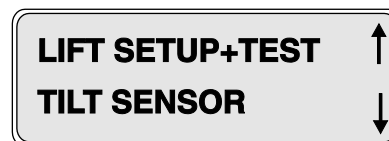

- 15 Press the Enter button.

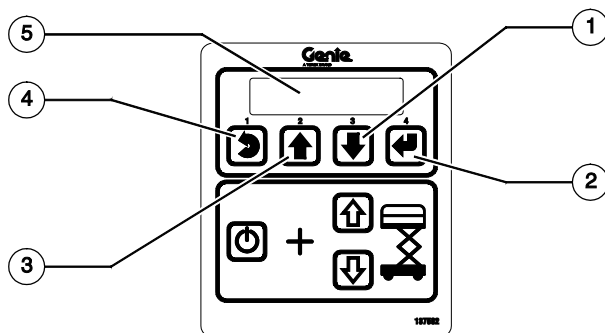

Ground Control Menu Buttons

- 1 scroll down button
- 2 enter button
- 3 scroll up button
- 4 escape button
- 5 LCD display

## Ground Controls

16 Press and hold the Enter button to start calibration.

- Result: An audible alarm will sound when calibration is complete.

Note: The machine will not calibrate if it is on a slope of one degree or greater.

Note: If the level sensor has been replaced, continue with step 24. If the level sensor was not replaced skip to step 27.



- 17 Raise the platform to approximately 1 ft / 30 cm.
- 18 Place a digital level on the ground control side of the drive chassis. Zero out the digital level.

19 Drive the steer end of the machine up a ramp until it is just under 3°.

- Result: No audible alarm is heard.
- ⊗ Result: An audible alarm is heard and Fault LL is displayed. Repeat this procedure starting at step 8 on a firm level surface.

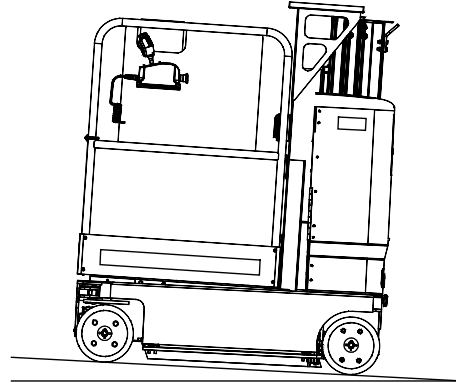

- 20 Continue driving the machine up the ramp until it is just over 3°.
- Result: An audible alarm is heard and Fault LL is displayed.
  - ⊗ Result: An audible alarm is not heard and Fault LL is not displayed. Repeat this procedure starting at step 8 on a firm level surface.

## Ground Controls

- 21 Drive the non-steer end of the machine up a ramp until it is just under 3°.

- ⦿ Result: No audible alarm is heard.
- ⊗ Result: An audible alarm is heard and Fault LL is displayed. Repeat this procedure starting at step 8 on a firm level surface.

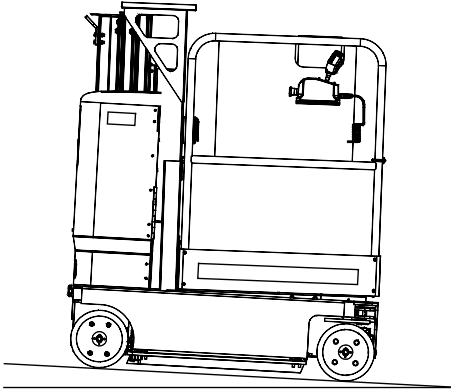

- 22 Continue driving the machine up the ramp until it is just over 3°.

- ⦿ Result: An audible alarm is heard and Fault LL is displayed.
- ⊗ Result: An audible alarm is not heard and Fault LL is not displayed. Repeat this procedure starting at step 8 on a firm level surface.

- 23 Place a digital level on the steer end of the drive chassis. Zero out the digital level.

- 24 Drive the ground control side of the machine onto a ramp until it is just under 1.5°.

- ⦿ Result: No audible alarm is heard.
- ⊗ Result: An audible alarm is heard and Fault LL is displayed. Repeat this procedure starting at step 8 on a firm level surface.

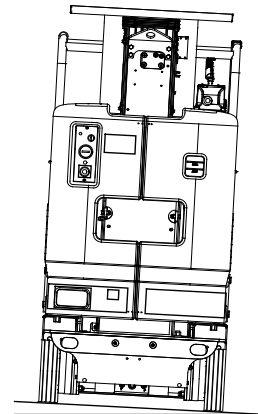

- 25 Continue driving the machine onto the ramp until it is just over 1.5°.

- ⦿ Result: An audible alarm is heard and Fault LL is displayed.
- ⊗ Result: An audible alarm is not heard and Fault LL is not displayed. Repeat this procedure starting at step 8 on a firm level surface.

## Ground Controls

- 26 Drive the hydraulic tank side of the machine onto a ramp until it is just under 1.5°.
- Result: No audible alarm is heard.
  - ☒ Result: An audible alarm is heard and Fault LL is displayed. Repeat this procedure starting at step 8 on a firm level surface.

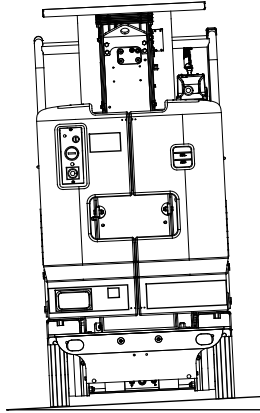

- 27 Continue driving the machine onto the ramp until it is just over 1.5°.
- Result: An audible alarm is heard and Fault LL is displayed.
  - ☒ Result: An audible alarm is not heard and Fault LL is not displayed. Repeat this procedure starting at step 8 on a firm level surface.
- 28 Lower the platform to the stowed position.

# Hydraulic Pump

## 3-1 Function Pump

The hydraulic pump is attached to the motor which makes up the hydraulic power unit.

### How to Test the Hydraulic Pump

Note: When removing a hose assembly or fitting, the O-ring (if equipped) on the fitting and/or hose end must be replaced. All connections must be torqued to specification during installation. Refer to Specifications, *Hydraulic Hose and Fitting Torque Specifications*.

- 1 Tag, disconnect and plug the high pressure hydraulic hose from the hydraulic pump.

#### **⚠ WARNING**

Bodily injury hazard. Spraying hydraulic oil can penetrate and burn skin. Loosen hydraulic connections very slowly to allow the oil pressure to dissipate gradually. Do not allow oil to squirt or spray.

- 2 Connect a 0 to 5000 psi / 0 to 350 bar pressure gauge to the high pressure port on the pump.
- 3 Turn the key switch to ground control and pull out the red Emergency Stop button to the on position at both ground and platform controls.

- 4 Activate the platform up function from the ground controls.
  - ⦿ Result: If the pressure gauge reads 3200 psi / 221 bar, immediately stop. The pump is good.
  - ⊗ Result: If the pressure gauge fails to reach 3200 psi / 221 bar, the pump is bad and will need to be serviced or replaced.

#### **NOTICE**

Component damage hazard. There is no relief valve in the hydraulic pump and the pump can be damaged if the pressure is allowed to exceed 3200 psi / 221 bar. When testing the pump, activate the pump in one second intervals until 3200 psi / 221 bar is confirmed. Do not over-pressurize the pump.

- 5 Remove the pressure gauge and reconnect the hydraulic hose. Torque to specifications.

## Hydraulic Pump

### How to Remove the Hydraulic Pump

Note: When removing a hose assembly or fitting, the O-ring (if equipped) on the fitting and/or hose end must be replaced. All connections must be torqued to specification during installation. Refer to Specifications, *Hydraulic Hose and Fitting Torque Specifications*.

- 1 Disconnect the battery pack from the machine.

**⚠ WARNING** Electrocutation/burn hazard. Contact with electrically charged circuits could result in death or serious injury. Remove all rings, watches and other jewelry.

- 2 Tag and disconnect the hydraulic power unit cables at the motor controller.
- 3 Disconnect the filter head from the filter head mounting bracket. Rotate the filter out and away from the hydraulic power unit.
- 4 Remove the hydraulic power unit retaining fasteners.
- 5 Tag, disconnect and plug the hydraulic tank hard line from the pump. Cap the fitting on the pump.

- 6 Tag, disconnect and plug the high pressure hose from the pump. Cap the fitting on the pump.

**⚠ WARNING** Bodily injury hazard. Spraying hydraulic oil can penetrate and burn skin. Loosen hydraulic connections very slowly to allow the oil pressure to dissipate gradually. Do not allow oil to squirt or spray.

- 7 Remove the hydraulic power unit from the machine.
- 8 Remove the pump mounting bolts. Carefully remove the pump.

**⚠ DANGER** Tip-over hazard. After replacing the hydraulic pump, it is critical to return the function speed settings to original factory specifications. Failure to restore the machine to original factory specifications could cause the machine to tip over resulting in death or serious injury.

## Function Manifold

### 4-1

#### Function Manifold Components

The function manifold is mounted next to the hydraulic power unit.

Index No.	Description	Schematic Item	Function	Torque
—	Coil nut (items E, F, and H)	—	—	5 ft-lbs / 7 Nm
1	Diagnostic port	A	Test port	—
2	Check disc	B	Steer circuit	18 ft-lbs / 24 Nm
3	Relief valve, 1800 to 3700 psi / 124 to 255 bar	C	Lift relief	20 ft-lbs / 27 Nm
4	Check valve, 10 psi / 0.7 bar	D	Drive circuit	20 ft-lbs / 27 Nm
5	Solenoid valve, 3 position 4 way	E	Drive forward/reverse	25 ft-lbs / 34 Nm
6	Solenoid valve, 3 position 4 way	F	Steer left/right	25 ft-lbs / 34 Nm
7	Flow regulator and relief valve, 0.75 gpm / 2.8 L/min 1500 psi / 130 bar	G	Steer circuit	26 ft-lbs / 35 Nm
8	Solenoid valve, 2 position 4 way	H	Platform up	25 ft-lbs / 34 Nm
9	Relief valve, 3500 psi / 241 bar maximum	I	System relief	20 ft-lbs / 27 Nm

# Function Manifold

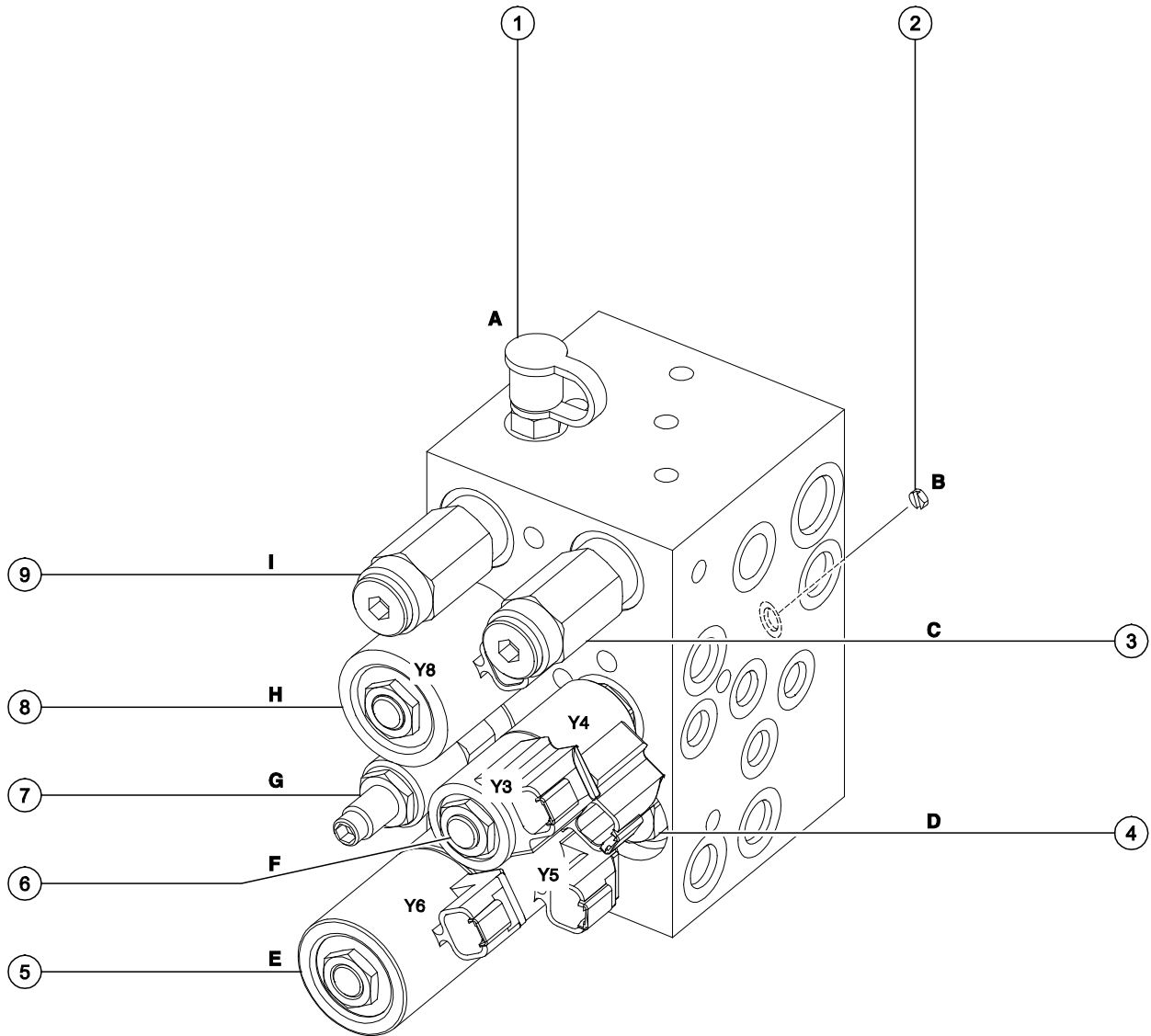

Note: 'alpha' callouts refer to corresponding notes on the hydraulic schematic.

Note: 'alpha-numeric' callouts refer to corresponding notes on the electrical schematic.

## Function Manifold

### 4-2 Valve Adjustments - Function Manifold

Note: Perform this test from the ground with the platform controls. Do not stand in the platform.

Note: Verify the hydraulic oil level is at the FULL mark on the hydraulic tank.

### How to Adjust the System Relief Valve

- 1 Locate the system relief valve on the function manifold (schematic item I).

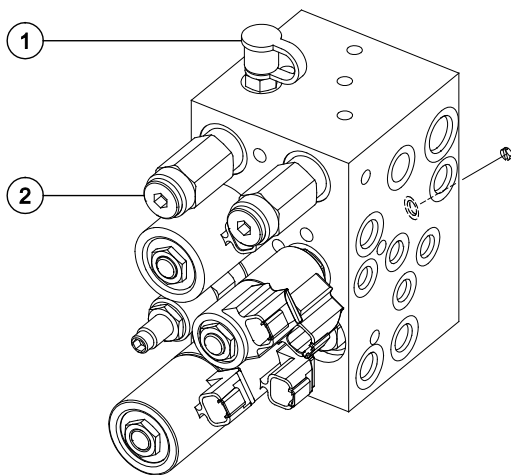

- 1 test port
- 2 system relief valve

- 2 Connect a 0 to 5000 psi / 0 to 350 bar pressure gauge to the test port on the function manifold (schematic item A).

- 3 Chock both sides of the wheels at the steer end of the machine.
- 4 Remove the platform controls from the platform.
- 5 Turn the key switch to platform controls and pull out the red Emergency Stop button to the on position at both ground and platform controls.
- 6 Move and hold the joystick fully in either direction while observing the pressure reading on the pressure gauge. Note the pressure. Refer to Specifications, *Hydraulic Component Specifications*.
- 7 Turn the machine off. Hold the system relief valve with a wrench and remove the cap (schematic item I).
- 8 Adjust the internal hex socket. Turn it clockwise to increase the pressure or counterclockwise to decrease the pressure.
- 9 Install the relief valve cap.
- 10 Repeat steps 5 and 6 to confirm the relief valve pressure.

## Function Manifold

### How to Adjust the Platform Lift Relief Valve

Note: Verify the system relief is adjusted correctly before performing this procedure.

Note: Perform this test from the ground with the platform controls. Do not stand in the platform.

Note: Verify the hydraulic oil level is at the FULL mark on the hydraulic tank.

- 1 Locate the lift relief valve on the function manifold (schematic item C).

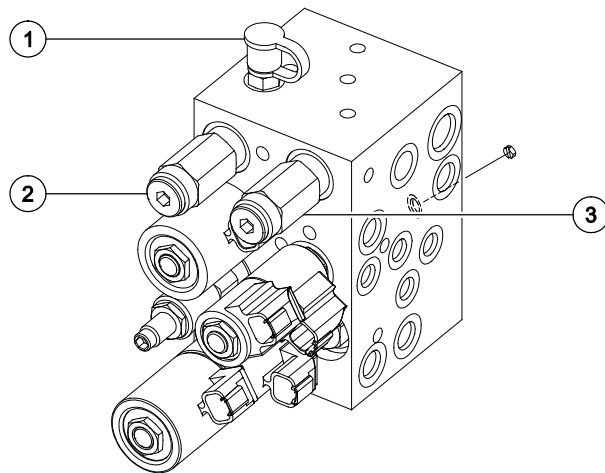

- 1 test port
- 2 system relief valve
- 3 lift relief valve

- 2 Connect a 0 to 5000 psi / 0 to 350 bar pressure gauge to the test port on the function manifold (schematic item A).
- 3 Place maximum rated load into the platform. Secure the load to the platform. Refer to Specifications, *Machine Specifications*.
- 4 Turn the key switch to platform controls and pull out the red Emergency Stop button to the on position at both ground and platform controls.
- 5 Remove the platform controls from the platform.
- 6 Hold the lift relief valve with a wrench and remove the cap (schematic item C).
- 7 While activating the platform up function, adjust the internal hex socket clockwise, just until the platform fully rises.
- 8 Fully lower the platform to the stowed position.
- 9 Add an additional 50 pounds / 22.7 kg to the platform. Secure the additional weight.
- 10 Attempt to raise the platform.
  - ⦿ Result: The power unit should **not** be able to lift platform.
  - ⊗ Result: If the power unit lifts the platform, adjust the internal hex nut socket counterclockwise until the platform will not rise.
- 11 Install the relief valve cap.
- 12 Remove the weight from the platform.

## Function Manifold

### How to Adjust the Steer Relief Valve

Note: Perform this test from the ground with the platform controls. Do not stand in the platform.

Note: Verify the hydraulic oil level is at the FULL mark on the hydraulic tank.

- 1 Locate the steer relief valve on the function manifold (schematic item G).

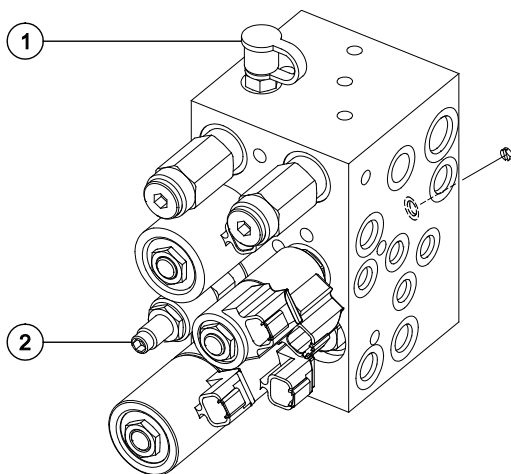

- 1 test port  
2 steer relief valve

- 2 Connect a 0 to 5000 psi / 0 to 350 bar pressure gauge to the test port on the function manifold (schematic item A).

- 3 Remove the platform controls from the platform.
- 4 Turn the key switch to platform controls and pull out the red Emergency Stop button to the on position at both ground and platform controls.
- 5 Activate the function enable switch and press and hold the steer thumb rocker switch to the right. Allow the wheels to completely turn to the right. Continue holding the switch while observing the pressure reading on the pressure gauge. Note the pressure. Refer to Specifications, *Hydraulic Component Specifications*.
- 6 Press and hold the steer thumb rocker switch to the left. Allow the wheels to completely turn to the left. Continue holding the switch while observing the pressure reading on the pressure gauge.
- 7 Turn the machine off. Hold the steer relief valve with a wrench and remove the cap (schematic item G).
- 8 Adjust the internal hex socket. Turn it clockwise to increase the pressure or counterclockwise to decrease the pressure.

**NOTICE** Component damage hazard. Do not adjust the relief valve pressures higher than specifications.

- 9 Install the relief valve cap.
- 10 Repeat steps 5 and 6 to confirm the relief valve pressure.

## Function Manifold

### 4-3 Valve Coils

#### How to Test a Coil

A properly functioning coil provides an electromagnetic force which operates the solenoid valve. Critical to normal operation is continuity within the coil. Zero resistance or infinite resistance indicates the coil has failed.

Since coil resistance is sensitive to temperature, resistance values outside specification can produce erratic operation. When coil resistance decreases below specification, amperage increases. As resistance rises above specification, voltage increases.

While valves may operate when coil resistance is outside specification, maintaining coils within specification will help ensure proper valve function over a wide range of operating temperatures.

#### **⚠ WARNING**

Electrocution/burn hazard. Contact with electrically charged circuits could result in death or serious injury. Remove all rings, watches and other jewelry.

Note: If the machine has been in operation, allow the coil to cool at least 3 hours before performing this test.

- 1 Tag and disconnect the wiring from the coil to be tested.
  - 2 Test the coil resistance using a multimeter set to resistance (W). Refer to the Valve Coil Resistance Specification table.
- ⊙ Result: If the resistance is not within the adjusted specification, plus or minus 10%, replace the coil.

### Valve Coil Resistance Specifications

Note: The following coil resistance specifications are at an ambient temperature of 68°F / 20°C. As valve coil resistance is sensitive to changes in air temperature, the coil resistance will typically increase or decrease by 4% for each 18°F / -7.7°C that your air temperature increases or decreases from 68°F / 20°C.

Description	Specification
Solenoid valve, 3 position 4 way, 20V DC with diode (schematic item E)	27.2Ω
Solenoid valve, 3 position 4 way, 20V DC with diode (schematic item F)	19Ω
Solenoid valve, 2 position 4 way, 20V DC with diode (schematic item H)	25Ω
Solenoid valve, 2 position 2 way, N.C. 20V DC with diode (schematic item N)	6.25Ω

## Function Manifold

### How to Test a Coil Diode

Genie incorporates spike suppressing diodes in all of its coils. Properly functioning coil diodes protect the electrical circuit by suppressing voltage spikes. Voltage spikes naturally occur within a function circuit following the interruption of electrical current to a coil. Faulty diodes can fail to protect the electrical system, resulting in a tripped circuit breaker or component damage.

**⚠ WARNING** Electrocutation/burn hazard. Contact with electrically charged circuits could result in death or serious injury. Remove all rings, watches and other jewelry.

- 1 Test the coil resistance. Refer to Repair Procedure, *How to Test a Coil*.
- 2 Connect a 10Ω resistor to the negative terminal of a known good 9V DC battery. Connect the other end of the resistor to a terminal on the coil.

Note: The battery should read 9V DC or more when measured across the terminals.

#### Resistor, 10Ω

Genie part number	27287
-------------------	-------

- 3 Set a multimeter to read DC amperage.

Note: The multimeter, when set to read DC amperage, should be capable of reading up to 800 mA.

- 4 Connect the negative lead to the other terminal on the coil.

Note: If testing a single terminal coil, connect the negative lead to the internal metallic ring at either end of the coil.

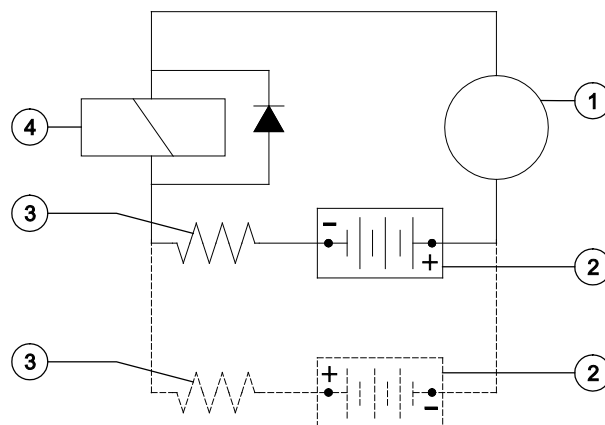

- 1 multimeter
- 2 9V DC battery
- 3 10Ω resistor
- 4 coil

Note: Dotted lines in illustration indicate a reversed connection as specified in step 6.

- 5 Momentarily connect the positive lead from the multimeter to the positive terminal on the 9V battery. Note and record the reading.
  - 6 At the battery or coil terminals, reverse the connections. Note and record the current reading.
- ⊙ Result: Both current readings are greater than 0 mA and are different by a minimum of 20%. The coil is good.
  - ⊗ Result: if one or both current readings are greater than 0 mA, or if the two current readings do not differ by a minimum of 20%, the coil and/or its internal diode are faulty and the coil should be replaced.

## Brake Release Hand Pump Components

### 5-1 Brake Release Hand Pump Components

The brake release hand pump manifold is mounted behind the the hydraulic power unit.

Index No.	Description	Schematic Item	Function	Torque
1	Hand pump	J	Manual brake release	30 ft-lbs / 41 Nm
2	Needle valve	K	Manual brake release enable	45-50 in-lbs / 5 Nm

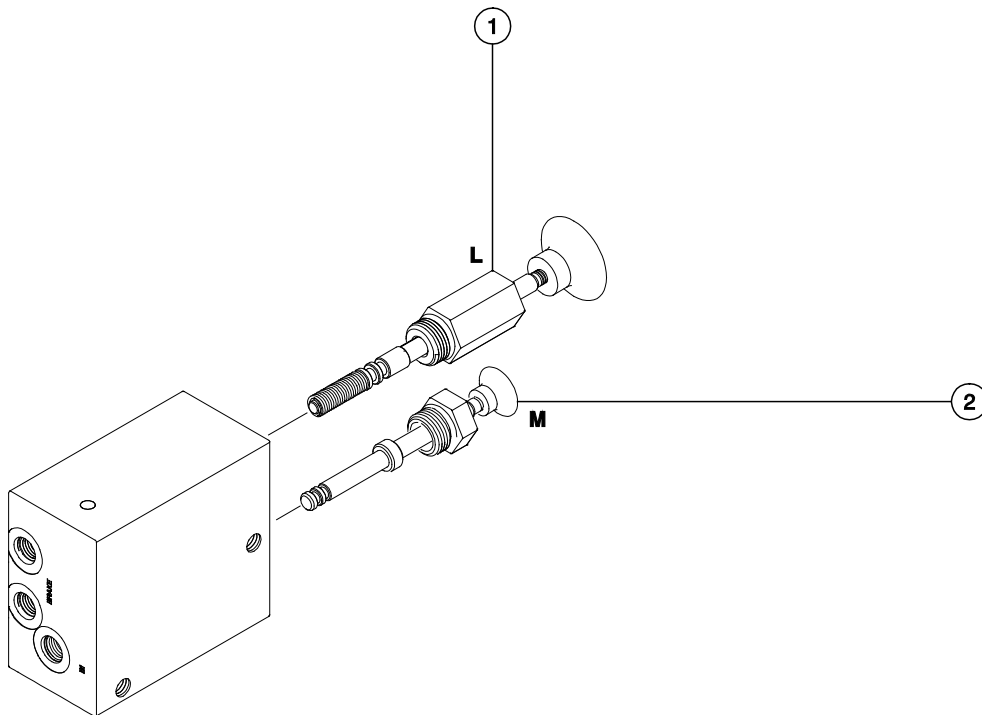

Note: 'alpha' callouts refer to corresponding notes on the hydraulic schematic.

# Hydraulic Tank

## 6-1 Hydraulic Tank

The primary functions of the hydraulic tank are to cool and deaerate the hydraulic fluid during operation. It utilizes internal suction strainers for the pump supply lines and has an external return line filter.

### How to Remove the Hydraulic Tank

**NOTICE** Component damage hazard. The work area and surfaces where this procedure will be performed must be clean and free of debris that could get into the hydraulic system.

Note: When removing a hose assembly or fitting, the O-ring (if equipped) on the fitting and/or hose end must be replaced. All connections must be torqued to specification during installation. Refer to Specifications, *Hydraulic Hose and Fitting Torque Specifications*.

Perform this procedure with the platform in the stowed position.

- 1 Tag, disconnect and plug the hydraulic supply hard line at the pump. Cap the fitting on the pump. Remove the hard line from the tank.

**WARNING** Bodily injury hazard. Spraying hydraulic oil can penetrate and burn skin. Loosen hydraulic connections very slowly to allow the oil pressure to dissipate gradually. Do not allow oil to squirt or spray.

- 2 Tag, disconnect and plug the return hard line at the hydraulic filter. Cap the fitting on the filter. Remove the hard line from the tank.

- 3 Remove the hydraulic tank retaining fasteners and remove the hydraulic tank from the machine.
- 4 Remove the hydraulic tank cap and drain the tank into a suitable container.

#### Torque specifications

Hydraulic retaining fasteners, dry	35 in-lbs 4 Nm
Hydraulic tank retaining fasteners, lubricated	26 in-lbs 2.9 Nm

## Non-Steer Axle Components

### 7-1 Drive Brake

#### How to Remove the Drive Brake

Note: When removing a hose assembly or fitting, the O-ring (if equipped) on the fitting and/or hose end must be replaced. All connections must be torqued to specification during installation. Refer to Specifications, *Hydraulic Hose and Fitting Torque Specifications*.

- 1 Block the steer wheels.
  - 2 Remove the cotter pin from the wheel castle nut.
- Note: Always replace the cotter pin with a new one when removing the castle nut.
- 3 Loosen the wheel castle nut. Do not remove it.
  - 4 Center a lifting jack under the drive chassis at the non-steer end of the machine.
  - 5 Raise the machine approximately 2 inches / 5 cm. Place blocks under the chassis for support.

**⚠ WARNING** Crushing hazard. The chassis will fall if not properly supported.

- 6 Remove the wheel castle nut. Remove the wheel.

- 7 Tag, disconnect and plug the hydraulic hose from the brake. Cap the fitting on the brake.

**⚠ WARNING** Bodily injury hazard. Spraying hydraulic oil can penetrate and burn skin. Loosen hydraulic connections very slowly to allow the oil pressure to dissipate gradually. Do not allow oil to squirt or spray.

- 8 Place a lifting jack under the brake for support.
- 9 Remove the fasteners that attach the brake to the drive chassis. Remove the brake.

**⚠ CAUTION** Crushing hazard. The brake will fall if not properly supported when the mounting fasteners are removed.

#### Torque specifications

Brake mounting fasteners, dry	75 ft-lbs 102 Nm
Brake mounting fasteners, lubricated	56 ft-lbs 76 Nm

## Steer Axle Components

### 8-1 Yoke and Drive Motor

#### How to Remove the Yoke and Drive Motor Assembly

Note: When removing a hose assembly or fitting, the O-ring (if equipped) on the fitting and/or hose end must be replaced. All connections must be torqued to specification during installation. Refer to Specifications, *Hydraulic Hose and Fitting Torque Specifications*.

- 1 Block the non-steer tires.
- 2 Remove the cotter pin from the wheel castle nut.
- Note: Always replace the cotter pin with a new one when removing the castle nut.
- 3 Loosen the wheel castle nut. Do not remove it.
- 4 Center a lifting jack under the drive chassis at the steer end of the machine.
- 5 Raise the machine approximately 6 inches / 15 cm. Place blocks under the chassis for support.

**⚠ WARNING** Crushing hazard. The chassis will fall if not properly supported.

- 6 Remove the wheel castle nut. Remove the wheel.

- 7 Tag, disconnect and plug the hydraulic hoses on the drive motor. Cap the fittings on the drive motor.

**⚠ WARNING** Bodily injury hazard. Spraying hydraulic oil can penetrate and burn skin. Loosen hydraulic connections very slowly to allow the oil pressure to dissipate gradually. Do not allow oil to squirt or spray.

**NOTICE** Component damage hazard. Hoses can be damaged if they are kinked or pinched.

- 8 Support and secure the yoke assembly to an appropriate lifting device.
- 9 Remove the retaining fastener from the steer link at the yoke assembly.

Note: While removing the retaining fasteners, take note of the quantity and location of the spacers when disconnecting the steer link from the yoke assembly.

- 10 Remove the retaining fastener from the top of the yoke pivot shaft.

Note: The pivot shaft retaining fastener is located above the main deck.

- 11 Lower the yoke assembly out of the chassis.

**⚠ CAUTION** Bodily injury hazard. The yoke/motor assembly may fall if not properly supported when it is removed from the chassis.

## Steer Axle Components

### How to Remove a Drive Motor

- 1 Block the non-steer tires.
- 2 Remove the cotter pin from the wheel castle nut of the motor to be removed.
- 3 Note: Always replace the cotter pin with a new one when removing the castle nut.
- 4 Loosen the wheel castle nut. Do not remove it.
- 5 Raise the machine approximately 2 inches / 5 cm. Place blocks under the chassis for support.

**▲WARNING** Crushing hazard. The chassis will fall if not properly supported.

- 6 Remove the wheel castle nut. Remove the wheel.
- 7 Tag, disconnect and plug the hydraulic hoses on the drive motor. Cap the fittings on the drive motor.

**▲WARNING** Bodily injury hazard. Spraying hydraulic oil can penetrate and burn skin. Loosen hydraulic connections very slowly to allow the oil pressure to dissipate gradually. Do not allow oil to squirt or spray.

**NOTICE** Component damage hazard. Hoses can be damaged if they are kinked or pinched.

- 8 Remove the drive motor mounting fasteners. Remove the motor.

#### Torque specifications

Drive motor mounting fasteners, dry	75 ft-lbs 101.7 Nm
Drive motor mounting fasteners, lubricated	56 ft-lbs 76.3 Nm

### 8-2

#### Steer Cylinder

### How to Remove the Steer Cylinder

Note: When removing a hose assembly or fitting, the O-ring (if equipped) on the fitting and/or hose end must be replaced. All connections must be torqued to specification during installation. Refer to Specifications, *Hydraulic Hose and Fitting Torque Specifications*.

- 1 Block the non-steer tires.
- 2 Remove the steer cylinder hose guard bracket from the machine.
- 3 Remove the pin retaining fasteners from the steer cylinder pivot pins. Remove the pins.

Note: While removing the pin retaining fasteners, take note of the quantity and location of the spacers when removing the pivot pin.

- 4 Remove the steer cylinder from the machine.
- 5 Tag, disconnect and plug the hydraulic hoses from the steer cylinder. Cap the fittings on the cylinder.

**▲WARNING** Bodily injury hazard. Spraying hydraulic oil can penetrate and burn skin. Loosen hydraulic connections very slowly to allow the oil pressure to dissipate gradually. Do not allow oil to squirt or spray.

**NOTICE** Component damage hazard. Hoses can be damaged if they are kinked or pinched.

---

# Steer Axle Components

## 8-3

### Steer Bellcrank

---

#### How to Remove the Tie Rod

- 1 Remove the steer cylinder. Refer to Repair Procedure, *How to Remove the Steer Cylinder*.
- 2 Center a lifting jack under the drive chassis at the steer end of the machine.
- 3 Raise the machine approximately 14 inches / 36 cm. Place blocks under the chassis for support.

**⚠ WARNING** Crushing hazard. The chassis will fall if not properly supported.

- 4 Turn the yokes fully to one side of the machine.
- 5 Remove the fasteners securing the tie rod to the steer yoke.

Note: Observe and note the quantity and location of the spacers between the tie rod and the steer links.

- 6 Turn the yokes fully to the opposite side of the machine.
- 7 Remove the fasteners securing the tie rod to the steer yoke.

Note: Observe and note the quantity and location of the spacers between the tie rod and the steer links.

- 8 Remove the bellcrank from the machine.

Note: Before re-installing the tie rod onto the machine, apply a small amount of removable thread lock onto the threads of the fasteners. Torque the fasteners to 31 ft-lbs / 42 Nm.

## Platform Components

### 9-1 Platform

---

#### How to Remove the Platform

Perform this procedure with the platform extension fully retracted and locked in position.

- 1 Raise the platform to approximately 1 ft / 30 cm.
- 2 Place support blocks between the platform and the drive chassis. Lower the platform onto the blocks.

**⚠ WARNING** Crushing hazard. Keep hands clear when lowering the platform.

- 3 Turn the key switch to the off position and disconnect the battery pack from the machine.

**⚠ WARNING** Electrocution/burn hazard. Contact with electrically charged circuits could result in death or serious injury. Remove all rings, watches and other jewelry.

- 4 Disconnect the platform controls from the control cable at the platform. Remove the platform controls from the platform and set the controls to the side.
- 5 Carefully cut the cable ties securing the control cable to the platform.

**NOTICE** Component damage hazard. The control cable can be damaged if cut while removing the cable ties.

- 6 Remove the fasteners securing the junction box bracket to the mast. Set the bracket and fasteners to the side.
- 7 Attach a lifting strap of suitable capacity from an overhead crane and center it around the platform railing. Support the platform. Do not apply any lifting pressure.
- 8 Remove the fasteners securing the platform mount to the mast and set the fasteners to the side. Remove the platform and mount from the machine.

**⚠ WARNING** Crushing hazard. The platform will fall if not properly supported.

## Platform Components

### 9-2 Platform Extension Deck

#### How to Remove the Platform Extension Deck

- 1 Turn the key switch to the off position.
- 2 Disconnect the battery pack from the machine.

#### **⚠ WARNING**

Electrocution/burn hazard. Contact with electrically charged circuits could result in death or serious injury. Remove all rings, watches and other jewelry.

- 3 Disconnect the platform controls from the control cable at the platform, and remove the platform controls from the platform. Set the platform controls to the side.
- 4 Slide the extension deck forward until the holes at the front of the extension deck are aligned with the fasteners of the slide blocks, at the front of the main deck.

- 5 Remove the fasteners securing the white slide blocks to the main deck. Set the slide blocks and the fasteners to the side.
- 6 Activate the foot release latch and slide the extension platform out of the platform.

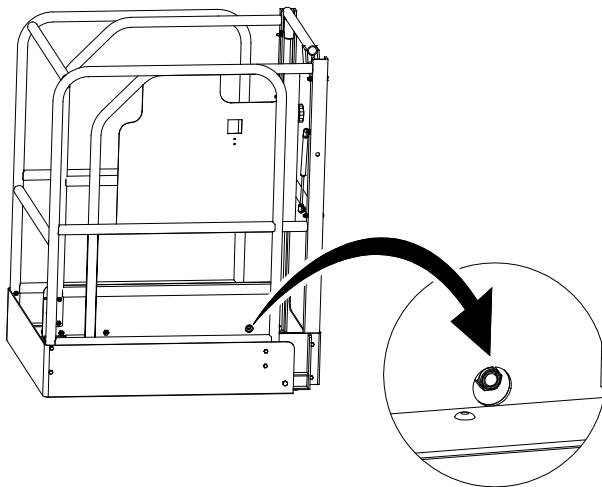

## Platform Components

### 9-3 Work Tray

#### How to Remove the Work Tray (if equipped)

- 1 Turn the key switch to the off position.
- 2 Disconnect the battery pack from the machine.

**⚠ WARNING** Electrocuting/burn hazard. Contact with electrically charged circuits could result in death or serious injury. Remove all rings, watches and other jewelry.

- 3 Disconnect the platform controls coil cord, from the control cable at the platform.
- 4 Remove the fasteners and spacer securing the platform controls to the platform controls mount. Remove the platform controls from the platform and set the controls to the side.
- 5 While supporting the work tray, remove the fasteners, bushings and spacers securing the work tray to the steer end, vertical platform rails. Set the fasteners, bushing and spacers to the side. Remove the work tray from the platform.

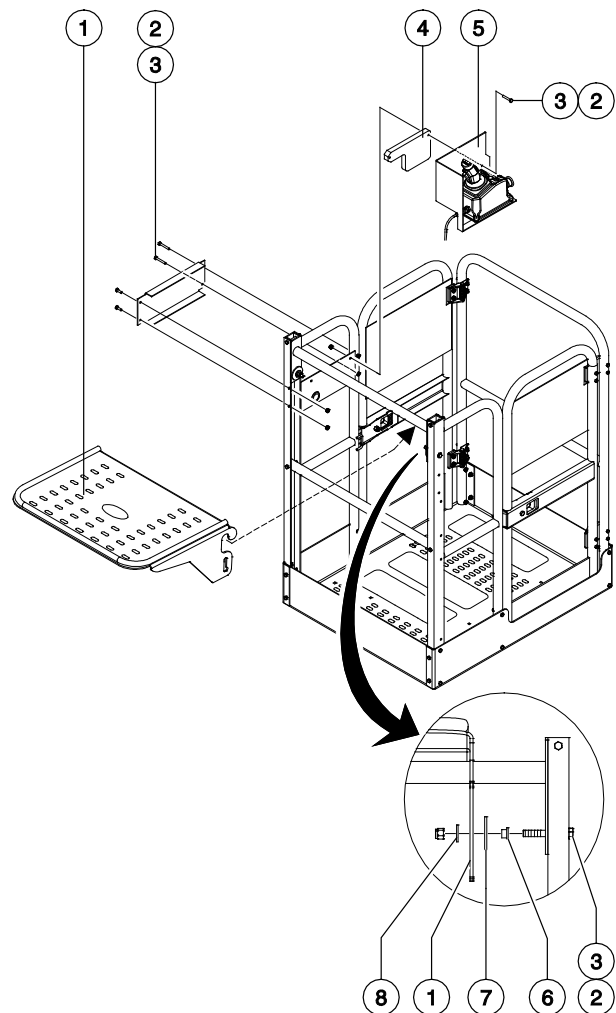

- 1 work tray
- 2 screw
- 3 nylock nut
- 4 platform controls spacer
- 5 platform controls assembly
- 6 bushing
- 7 spacer
- 8 washer

# Mast Components

## 10-1 Mast

### How to Remove the Mast Assembly

**▲WARNING** Bodily injury hazard. This procedure requires specific repair skills, lifting equipment and a suitable workshop. Attempting this procedure without these skills and tools could result in death or serious injury and significant component damage. Dealer service is strongly recommended.

Note: When removing a hose assembly or fitting, the O-ring (if equipped) on the fitting and/or hose end must be replaced. All connections must be torqued to specification during installation. Refer to Specifications, *Hydraulic Hose and Fitting Torque Specifications*.

Note: Perform this procedure on a firm, level surface with the machine in the stowed position.

- 1 Remove the Platform. Refer to Repair Procedure, *How to Remove the Platform*.
- 2 Tag and disconnect the power to platform wire harness at the quick disconnect near the Electronic Control Module (ECM).
- 3 Tag and disconnect the ECM wire harness at the quick disconnect near the ECM.
- 4 Attach a lifting strap of suitable capacity from an overhead crane to the lifting eye at the top of the mast. Support the mast. Do not apply any lifting pressure.

- 5 Tag, disconnect and plug the lift cylinder hoses at the function manifold. Cap the fittings.

**▲WARNING** Bodily injury hazard. Spraying hydraulic oil can penetrate and burn skin. Loosen hydraulic connections very slowly to allow the oil pressure to dissipate gradually. Do not allow oil to squirt or spray.

- 6 Remove the fasteners securing the lower rear access cover to the chassis and remove the cover. Set the cover and the fasteners to the side.
- 7 Tag and disconnect the wire harness from the platform down valve coil at the base of the lift cylinder.
- 8 Remove the retaining nut securing the platform down coil to the platform down solenoid valve and remove the coil. Set the coil and retaining nut to the side.
- 9 Remove the platform down solenoid valve from the lift cylinder. Set the valve to the side and plug the cylinder port.

**▲WARNING** Bodily injury hazard. Spraying hydraulic oil can penetrate and burn skin. Loosen hydraulic connections very slowly to allow the oil pressure to dissipate gradually. Do not allow oil to squirt or spray.

- 10 Remove the mast retaining fasteners.

## Mast Components

- 11 Carefully pull the hydraulic hoses free while removing the mast from the machine.

**⚠ WARNING** Crushing hazard. The mast assembly could become unbalanced and fall if not properly supported when removed from the machine.

**NOTICE** Component damage hazard. Hoses and cables can be damaged if they are kinked or pinched.

- 12 Place the mast assembly on a suitable structure capable of supporting it.

### How to Disassemble the Mast

**⚠ WARNING** Bodily injury hazard. This procedure requires specific repair skills, lifting equipment and a suitable workshop. Attempting this procedure without these skills and tools could result in death or serious injury and significant component damage. Dealer service is strongly recommended.

- 1 Remove the Mast. Refer to Repair Procedure, *How to Remove the Mast Assembly*.
- 2 Rotate the mast until the carriage is facing up.
- 3 Remove the socket head retaining fastener from the clevis block on the lift cylinder rod end at the top of the number 1 column.

# Mast Components

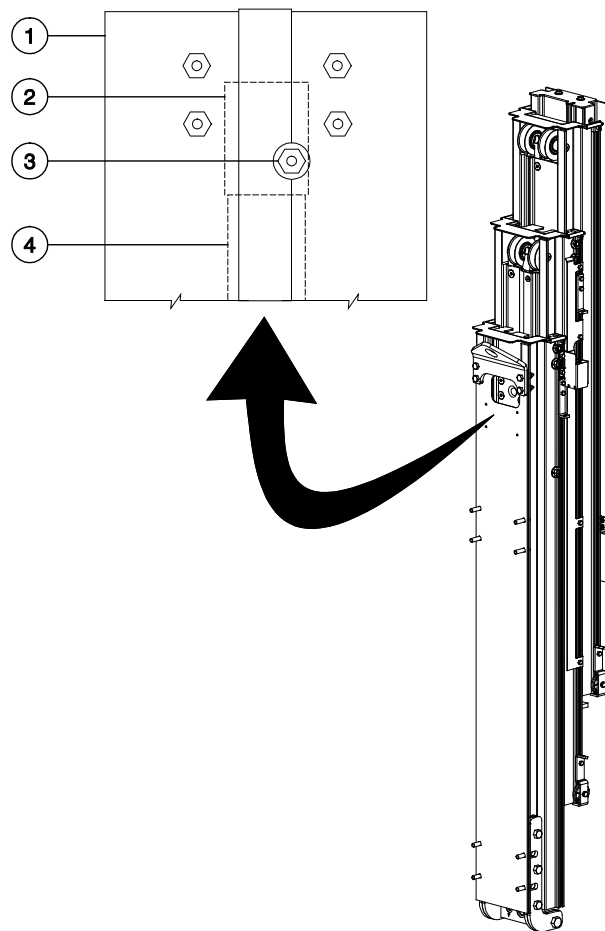

- 1 top of number 1 column
- 2 clevis block (not shown)
- 3 clevis block fastener
- 4 lift cylinder (not shown)

4 Remove the lift cylinder barrel end mounting fasteners.

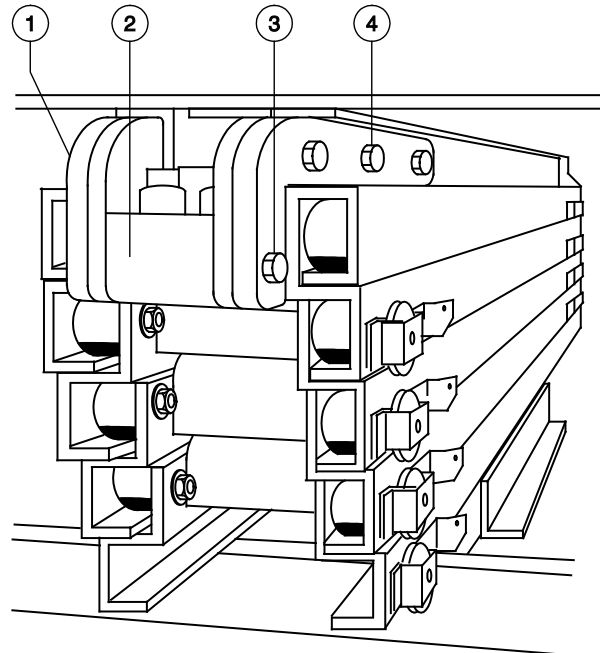

- 1 cylinder mounting plate
- 2 cylinder
- 3 cylinder mounting bolt
- 4 plate mounting fasteners

- 5 Loosen the lift cylinder mounting bracket fasteners.
- 6 Support the cylinder and carefully slide it out of the mast assembly.

**CAUTION** Crushing hazard. The lift cylinder will become unbalanced and fall if not properly supported and secured to the lifting device.

- 7 Remove the cover from the top of each column.
- 8 Remove the adjustment nuts from all of the sequencing cables.
- 9 Slide the carriage toward the top of the mast assembly enough to remove the tension on the lifting chains.

## Mast Components

- 10 Slide the column below the carriage toward the top of the mast assembly approximately 6 inches / 15 cm to access the idler wheel mounting fasteners.
- 11 Hold the idler wheel axle from turning by placing a screwdriver through the hole in the axle. Remove the axle mounting fasteners and remove the idler wheel assembly.

Note: Label the location and orientation of each idler wheel assembly.

- 12 Remove the adjustment nuts from the chain tension rocker on the carriage.
- 13 Slide the carriage out the bottom of the mast assembly.
- 14 Lay the chains out on the floor at the top of the mast.

Note: Do not allow the chains to become twisted or dirty.

- 15 Remove the adjustment nuts from the chain tension rocker on the column.
- 16 Remove the column by sliding the column out the bottom of the mast.
- 17 Push the next column toward the top of the mast to access the idler wheel assembly mounting fasteners.
- 18 Hold the idler wheel axle from turning by placing a screwdriver through the hole in the axle. Remove the axle mounting fasteners, and remove the idler wheel assembly.
- 19 Remove the adjustment nuts from the chain tension rocker on the column.
- 20 Slide the column out the bottom of the mast.
- 21 Repeat steps 17 through 20 for each remaining column.

Note: If the chains are to be removed, mark the location and label each chain before removal.

### How to Assemble the Mast

**▲ WARNING** Bodily injury hazard. This procedure requires specific repair skills, lifting equipment and a suitable workshop. Attempting this procedure without these skills and tools could result in death or serious injury and significant component damage. Dealer service is strongly recommended.

- 1 Thoroughly clean all columns.
- 2 Secure the number 1 column to the work table and lay the chains out on the floor.

Note: Do not allow the chains to become twisted or dirty.

- 3 Apply a generous amount of Boelube® wax to the inside and outside channels of each column.
- 4 Slide the number 2 column into the number 1 column.
- 5 Lay the number 2 column chains on the floor.

Note: Do not allow the chains to become twisted or dirty.

- 6 Lay the number 1 column chains inside the number 2 column.
- 7 Slide the number 3 column into the number 2 column.
- 8 When the number 3 column is almost all the way in, guide the number 1 column chains into the chain tension rocker on the number 3 column.
- 9 Install the adjustment nuts on the number 1 column chains. Tighten the adjustment nuts until the lifting chains have equal tension and the chain tension rocker is centered in the inspection hole in the column.

## Mast Components

- 10 Lay the number 3 column chains on the floor.

Note: Do not allow the chains to become twisted or dirty.

- 11 Lay the number 2 column chains inside the number 3 column.
- 12 Follow steps 4 through 11 for each remaining column and the carriage.
- 13 After all the columns are assembled, the idler wheel assemblies can be installed.
- 14 Remove the tension from the lifting chains on the number 2 column by pushing the number 3 column towards the top of the mast.
- 15 Install the idler wheel assembly in the top of the number 2 column. Tighten the mounting fasteners.

Note: Confirm that all idler wheels rotate smoothly with no excessive side movement, or rub on the inside of the column. Replace worn shims if necessary.

- 16 Repeat steps 14 and 15 for each remaining idler wheel assembly.
- 17 Confirm that all of the idler wheel axle mounting fasteners are flush with the column.

**NOTICE** Component damage hazard. The roller wheels may be damaged if the idler wheel axle mounting fasteners are not flush with the column.

- 18 Install the mast assembly on the drive chassis. Adjust the lifting chains. Refer to Repair Procedure, *How to Adjust the Lifting Chains*.

## 10-2 Glide Pads

Glide pads, used on the GR-12, GR-15, QS-12R, QS-15R, QS-12W and QS-15W, and wear pads used on the GR-20, QS-20R and QS-20W, are used to provide a uniform fit between the columns as the mast extends and retracts. Over time, it may be necessary to adjust the glide pads to ensure good machine performance.

Wear pads are not adjustable and do not require servicing on the GR-20, QS-20R and QS-20W.

### How to Adjust the Glide Pads

- 1 Locate the upper and lower glide pad adjustment bolts below each upper roller bolt, on both sides of each column.
- 2 Hold the glide pad adjustment bolt and loosen the lock nut on all glide pads.
- 3 Turn the glide pad adjustment bolt clockwise until the glide pad makes contact with the column. Adjust the glide pads on both sides of all columns. Be sure the sides of the columns are even to within 1/8 inch / 3 mm of each other.
- 4 On the number 1 column, secure the upper and lower glide pad bolts on both sides of the mast. Hold the glide pad adjustment bolt and torque the lock nut to 12 in-lbs / 1.35 Nm. Be sure the glide pad bolt does not turn.
- 5 Repeat step 4 for the upper and lower glide pads on both sides of the each column of the mast, Start with the number 2 column and work toward the carriage.

## Mast Components

### 10-3 Lifting Chains

#### How to Adjust the Lifting Chains

- 1 Mark the column to be adjusted.
- 2 Raise the platform approximately 6 feet / 2 m.
- 3 Place a lifting strap of suitable capacity from an overhead crane under the platform. Support the platform. Do not apply any lifting pressure.

#### NOTICE

Component damage hazard. The platform railings can be damaged if they are used to lift the platform. Do not attach the lifting strap to the platform railings.

Turn the adjustment lock nuts evenly on both sides of the chain tension rocker clockwise to raise the column or counterclockwise to lower the column.

Note: The chain tensioner rocker is located near the bottom of each column.

- 4 Fully lower the platform and confirm the alignment of the columns. Repeat steps 2 through 5 if necessary.
- 5 Confirm that the chain tensioner bracket is centered in the inspection hole.

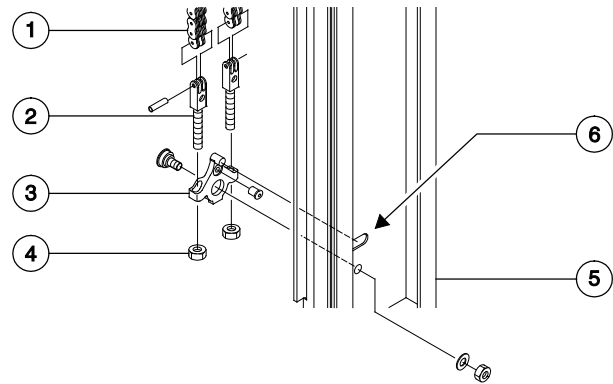

- 1 lifting chain
- 2 chain terminal
- 3 chain tension rocker
- 4 adjustment lock nut
- 5 mast column
- 6 inspection hole

## Mast Components

### How to Inspect the Lifting Chains

Inspection	Procedure	Inspection Failure	Inspection Remedy
<b>Wear</b>	Count out 16 chain links and measure pin to pin centerline dimension with a steel measuring tape.  Note: Measure a section of chain that moves over the idler wheels.	When the length of the 16 links (pin to pin) measure more than 8.25 inches / 21 cm for 1/2 inch / 12.7mm chain or 10.31 inches / 26.1 cm for 5/8 inch / 15.9 mm chain.	Replace both chains on that column. Replace entire chain. Do not repair just the affected portion of the chain.
<b>Rust and Corrosion</b>	Visually inspect the chains for rust and corrosion.	Evidence of rust or corrosion.	Remove chain and inspect for cracked plates (see inspection of cracked plates). If no cracks are found, lubricate chain with motor oil (SAE 40) and install chain.
	Visually inspect the chains for lubrication.	When external surfaces are not protected with a layer of oil.	Lubricate chain with motor oil (SAE 40W).
<b>Tight Joints</b>	Inspect chain link joints for easy movement.	Joints that do not flex freely or are binding.	If rust and corrosion is found, refer to Failure Remedy for rust and corrosion.  If link plates or pins are bent or deformed, replace entire chain. Replace both chains on that column. Do not repair just the affected portion of the chain.

# Mast Components

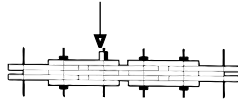
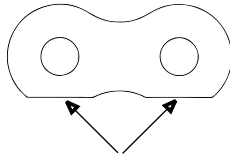
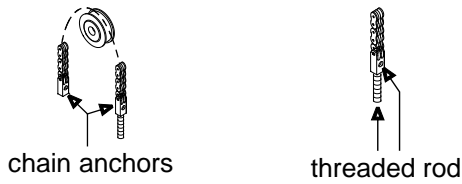
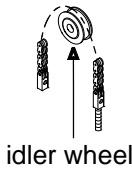
Inspection	Procedure	Inspection Failure	Inspection Remedy
<b>Raised or Turned Pins</b>	Visually inspect for raised pins.	Raised pins. 	Replace both chains on that column section. Do not repair just the affected portion of the chain.
	Visually inspect for turned pins by insuring all the flats on the "V" heads are aligned.	Misalignment of flats on all "V" heads.	Replace both chains on that column section. Do not repair just the affected portion of the chain.
<b>Chain Side</b>	Visually inspect for wear patterns on heads of link pins and outside link plates where they contact the idler wheel.	Wear on pin heads or noticeable wear in the profile of the outside link plate. 	Replace both chains on that column section. Do not repair just the affected portion of the chain.
		link plate wear	Check alignment of chain anchors and idler wheels.
<b>Chain Anchors</b> 	Visually inspect chain anchors.	Broken chain anchor fingers.	Replace chain anchor.
		Bent or damaged anchor.	Replace chain anchor.
		Twisted or misaligned chain anchor.	Re-align chain anchor to ensure even loading of chain.
		Threaded rod not visible in inspection hole.	Replace chain anchor and threaded rod.
<b>Idler Wheels</b> 	Visually inspect chain idler wheels.	Idler wheels have badly worn flanges.	Replace idler wheel and check chain alignment.
		Idler wheels have grooves worn into chain contact surface.	Replace idler wheel.
<b>Cracked Link Plates</b>	Visually inspect chain link plates for cracks.	Cracks in any chain link plate.	Replace both chains on that column section. Replace entire chain. Do not repair just the affected portion of the chain.

# Mast Components

## 10-4 Lift Cylinder

The lift cylinder is equipped with a normally closed solenoid valve to prevent movement in the event of a hydraulic line failure.

### How to Remove the Lift Cylinder

**⚠ WARNING** Bodily injury hazard. This procedure requires specific repair skills, lifting equipment and a suitable workshop. Attempting this procedure without these skills and tools could result in death or serious injury and significant component damage. Dealer service is strongly recommended.

- 1 Remove the Mast. Refer to Repair Procedure, *How to Remove the Mast Assembly*.
- 2 Rotate the mast until the carriage is facing down.
- 3 Remove the socket head retaining fastener from the clevis block on the lift cylinder rod end at the top of the number 1 column.
- 4 Remove the lift cylinder barrel end mounting fasteners.
- 5 Loosen the lift cylinder mounting bracket fasteners.
- 6 Support the cylinder and carefully slide it out of the mast assembly.

**⚠ WARNING** Crushing hazard. The lift cylinder could become unbalanced and fall if not properly supported and secured to the lifting device.

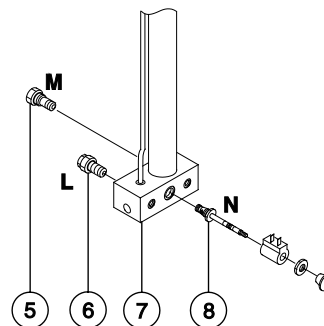
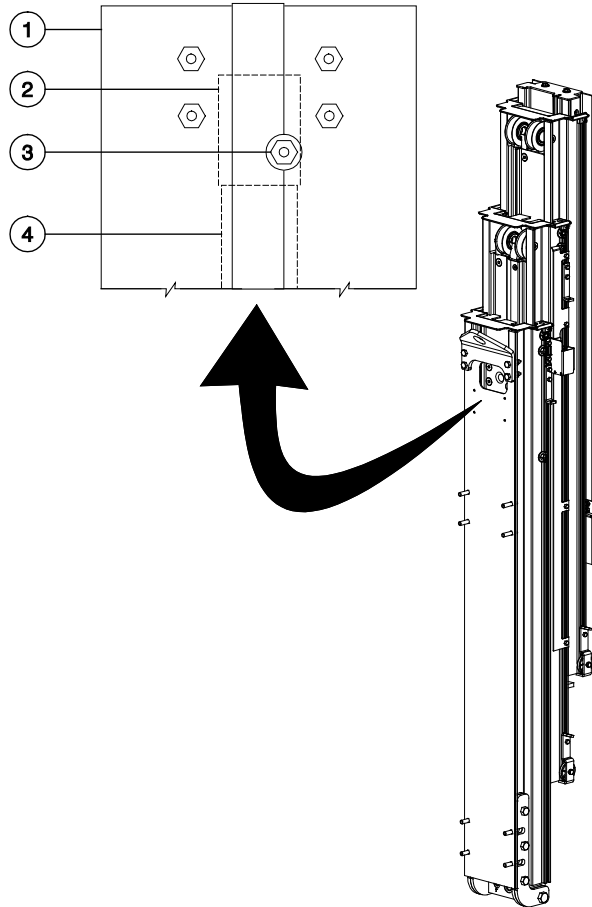

- 1 top of number 1 column
- 2 clevis block (not shown)
- 3 clevis block fastener
- 4 lift cylinder (not shown)
- 5 check valve
- 6 flow control
- 7 cylinder
- 8 manual lowering valve

## Platform Overload Components

### 11-1 Platform Overload System (if equipped)

#### How to Calibrate the Platform Overload System

Note: Perform this procedure with the machine on a firm, level surface.

- 1 Raise the platform approximately 2 feet / 70 cm.
- 2 At the platform junction box, tag and disconnect the load sense limit switch wire harness. The red and orange wires disconnect from white wire, the black wire disconnects from the red/black wire and the white wire disconnects from the yellow wire.

Note: The load sense limit switch is located near the platform support.

- 3 Set a multi-meter to measure continuity. Connect the leads from the multi-meter to the red and white wires disconnected in step 2.
- 4 Determine the maximum platform capacity. Refer to the machine serial plate.
- 5 Using a suitable lifting device, place a test weight equal to that of the maximum platform capacity at the center of the platform floor. Secure the weight to the platform. Refer to the chart below.

---

#### GR-12 and GR-15

Standard Platform	500 lbs 227 kg
-------------------	-------------------

---

#### GR-20

Standard Platform	350 lbs 159 kg
-------------------	-------------------

---

#### GR-12, GR-15 and GR-20

AWP Platform	350 lbs 159 kg
--------------	-------------------

---

#### QS-12R, QS-15R, QS-12W and QS-15W

Stockpicker Platform	500 lbs 227 kg
----------------------	-------------------

---

#### QS-20R and QS-20W

Stockpicker Platform	350 lbs 159 kg
----------------------	-------------------

---

## Platform Overload Components

### Determine the limit switch trigger point:

- 6 Gently move the platform up and down by hand, so it bounces 1 to 2 inches / 2.5 to 5 cm.
- 7 Check the continuity between the red and white wires originating from the limit switch of the platform overload assembly.
  - ⦿ Result: There is no continuity. Slowly tighten the load spring adjustment nut by turning it clockwise just until the limit switch closes and shows continuity.
  - ⦿ Result: There is continuity. Slowly loosen the load spring adjustment nut by turning it counterclockwise just until the limit switch opens and shows no continuity.

Note: The platform will need to be continuously moved up and down while making adjustments.

### Fine adjustment of the switch trigger point:

- 8 Continue moving the platform up and down and adjust the load spring adjustment nut clockwise or counterclockwise just until the limit switch is alternately opening and closing.

Note: When the limit switch is adjusted correctly, there will be continuity slightly longer than no continuity.

- 9 Remove the continuity tester from the limit switch wires. At the junction box, securely install the wires onto the limit switch harness.

### Confirm the setting:

- 10 Turn the key switch to platform control.
- 11 Lift the test weight off the platform floor using a suitable lifting device.
- 12 Place the test weight back onto the platform floor using a suitable lifting device.
  - ⦿ Result: The LCD display at the ground controls will show the machine model and hour meter information, indicating a normal condition, and the LED display at the platform controls will show the battery condition.

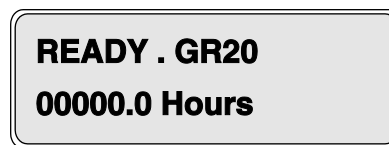

LCD Readout



LED Readout

## Platform Overload Components

- 13 Add an additional weight to the platform not to exceed 20% of the maximum rated load. Refer to the machine serial plate.
- ⦿ Result: The LCD display at the ground controls will show "OL: Platform Overloaded" and the LED display at the platform controls will show "OL". The platform overload system is operating properly. Refer to examples below.



LCD Readout

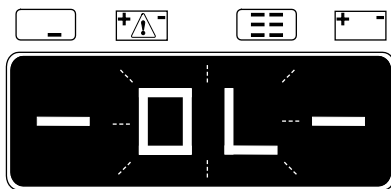

LED Readout

- ⊗ Result: The LCD display at the ground controls will show the machine model and hour meter information and the LED display at the platform controls will show the battery condition. The platform overload system is not operating properly. Repeat this procedure beginning with step 1.
- 14 Test all machine functions from the platform controls.
- ⦿ Result: All platform control functions should not operate.
- 15 Turn the key switch to ground control.
- 16 Test all machine functions from the ground controls.
- ⦿ Result: All ground control functions should not operate.

### 11-2 Platform Overload Recovery Message

If the ground controls LCD screen displays **OL: PLATFORM OVERLOADED**, the emergency lowering system has been used while the platform was overloaded.

#### How to Clear the Platform Overload Recovery Message

Note: This message shall be cleared by a person trained and qualified on the troubleshooting and repair of this machine.

Note: Use the following chart to identify the description of each LCD screen control button used in this procedure.



Escape

Scroll up

Scroll down

Enter

- 1 Turn the key switch to the ground controls position and pull out the red Emergency Stop button to the on position at the platform controls.
- 2 Press and hold the ground control **scroll up** and **scroll down** buttons.

# Platform Overload Components

3 Pull out the red Emergency Stop button at the ground controls.

⦿ Result: The ground control LCD display will show the following.



4 Press the **scroll down** button.

⦿ Result: The ground control LCD display will show the following.

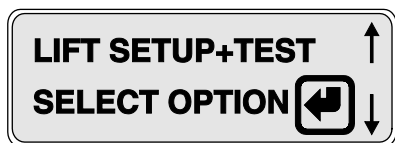

5 Press the **enter** button.

⦿ Result: The ground control LCD display will show the following.

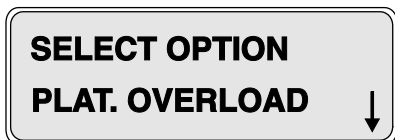

6 Press the **enter** button.

⦿ Result: The ground control LCD display will show the following.



7 Press and hold the **scroll down** button for 5 seconds.

⦿ Result: The ground control LCD display will show the following.

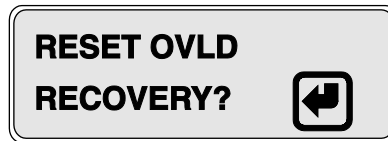

8 Press the **enter** button.

⦿ Result: The ground control LCD display will show the following.

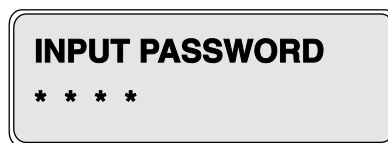

9 Press the buttons in the following sequence: **(down)(down)(up)(enter)**.

Note: After each key press an asterisk (\*) will appear on the second line of the LCD display.

⦿ Result: The ground control LCD display will show the following.



Note: After 3 seconds the LCD display will return to **SELECT OPTION PLAT. OVERLOAD**.

10 Push in the red Emergency stop button.

## Obstruction Sensing System

### 12-1 Obstruction Sensing Pads

The function of the Obstruction Sensing System is to detect a person or an object standing on the machine chassis. When a person or an object is detected on top of the machine chassis, the machine platform down function will not operate, and an alarm will sound. The LCD readout at the ground controls will display OAC: Obstruction Above Chassis and the LED readout on the platform controls will display OAC. Refer to the examples below.

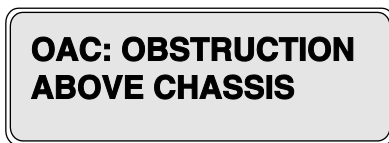

LCD Readout

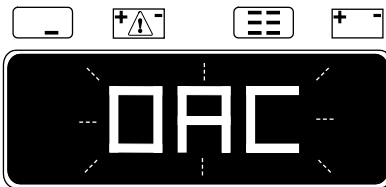

LED Readout

### How to replace an Obstruction Sensing Pad (QSR models)

- 1 QS-12R: Raise the platform approximately 3 feet / 1 m.  
QS-15R and QS-20R: Raise the platform approximately 5 feet / 1.5 m.
- 2 Open the battery cover. Rest the cover against the chassis.
- 3 Lower the platform until the mast just contacts the battery cover.

**⚠ WARNING** Crushing hazard. Keep hands clear of the battery cover when lowering the platform.

Turn the key switch to the off position and disconnect the battery pack from the machine.

**⚠ WARNING** Electrocuting/burn hazard. Contact with electrically charged circuits could result in death or serious injury. Remove all rings, watches and other jewelry.

## Obstruction Sensing System

- 4 At the non-steer end of the machine, unlatch the covers and open the ground controls cover.
- 5 Working with the obstruction sensing pad to be replaced, locate the pad cables.
- 6 Carefully pull the cables to identify the connector cable located at the ground controls, non-steer end of the machine.
- 7 After the connector cable has been identified, tag and disconnect the cable from the obstruction sensing pad cables.

Note: If the ground controls side or battery box cover obstruction sensing pad is replaced, carefully remove the appropriate pin from the male Deutsch connector. A new Deutsch pin will have to be installed onto the cable wire of the new ground controls side pad, or battery box cover pad.

- 8 Using a broad flat metal blade, carefully slide the metal blade under the obstruction pad and work the metal blade under the entire pad to be replaced, until the pad is separated from the chassis or the battery box cover.
- 9 Remove the pad from the machine and carefully scrape away any excess adhesive from the chassis or battery box cover.
- 10 Using a suitable solvent, clean the surface where the obstruction sensing pad was removed. Allow the surface to dry thoroughly.
- 11 Install the new obstruction sensing pad.

Note: It may be necessary to use touch-up paint in the area where the obstruction sensing pad was removed. Let the paint dry completely, before installing the new obstruction sensing pad.

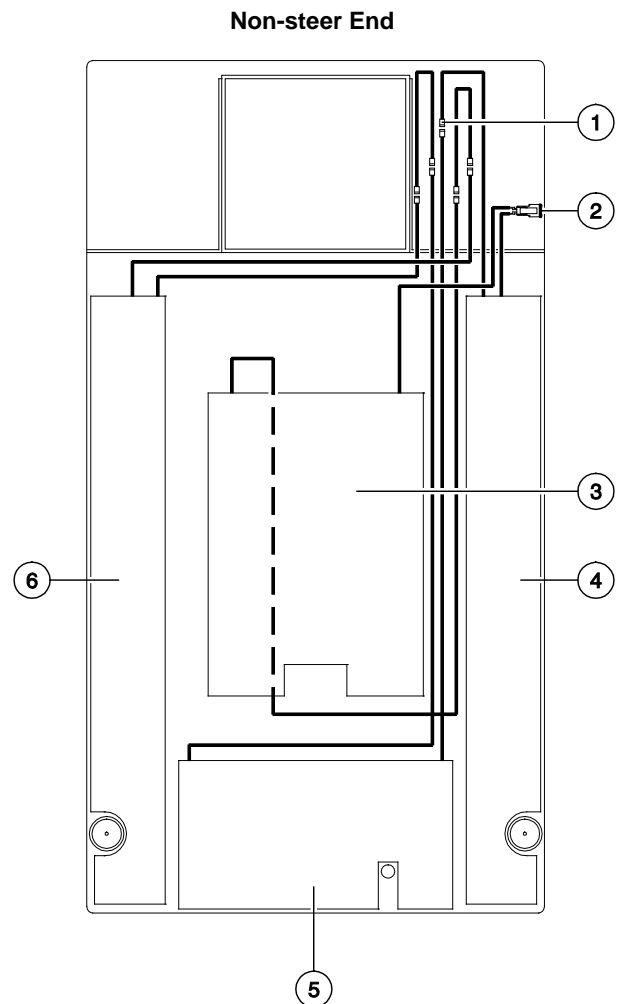

### Steer End

#### Obstruction Sensing Pads

- 1 cable connectors
- 2 Deutsch connector
- 3 battery box obstruction sensing pad
- 4 ground controls side obstruction sensing pad
- 5 steer end obstruction sensing pad
- 6 hydraulic tank side obstruction sensing pad

# Battery Charger

## 13-1 Battery Charger

The charger contains selectable charging profiles stored in its internal memory to charge batteries. These profiles are specific to each battery type. The charging profile must be programmed to match the specific battery type on the machine.

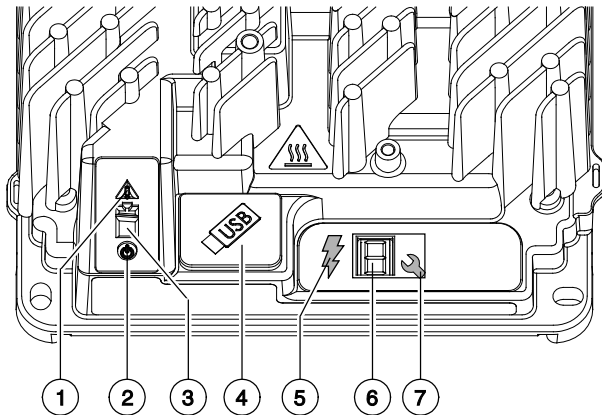

Charger status indicators

- 1 Error / Fault indicator
- 2 AC status indicator
- 3 Charging status
- 4 USB port
- 5 Charging indicator
- 6 Charger display
- 7 Charge profile selection button

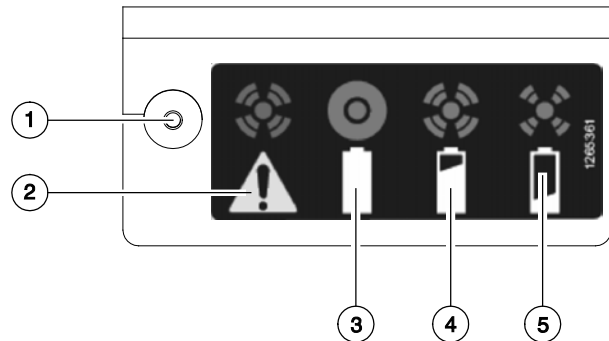

Remote charger status indicators

- 1 Error / Fault indicator
- 2 Error / Fault
- 3 Charge complete
- 4 Charging, high state of charge
- 5 Charging, low state of charge

# Battery Charger

## Selecting a Charge Profile

### **⚠ WARNING**

Electrocution/burn hazard. Contact with electrically charged circuits could result in death or serious injury. Remove all rings, watches and other jewelry.

- 1 At the ground controls, turn the key switch to the off position and push in the red Emergency Stop button to the off position.
- 2 Open the battery compartment.
- 3 Press and hold the charge profile selection button and plug the battery charger into an AC power source. Continue to hold the button until the amber error indicator is on and the green charging indicator light is flashing. Release the button.
- 4 Press and release the charge profile selection button to navigate to the charge profile appropriate for your machine and battery type. Refer to the chart below.

Profile	Description
P001	Scissor, GR, GRC, QS (does not include GS-4047) - Flooded lead acid batteries - Temperature compensated *
P003	Scissor, GR, GRC, QS (does not include GS-4047) - Flooded lead acid batteries - Not temperature compensated **
P007	GS-4047 - Flooded lead acid batteries - Not temperature compensated **
P043	All Scissors, GR, GRC, QS - AGM batteries - Temperature compensated *

\* Temperature compensated: Battery temperature sensor has been installed on the machine.

\*\* Not temperature compensated: Battery temperature sensor has not been installed on the machine.

- 5 Press and hold the charge profile selection button until the error indicator and charging indicator lights turn off and the AC status indicator light turns on to confirm selection and exit charge profile mode. Release the button.

Note: Charge profile mode will time out and exit if there is 15 seconds of inactivity, the charge profile number has been displayed three times or the AC power source had been disconnected.

- 6 Press and release the charge profile selection button to confirm the correct charge profile has been selected.

## Diagnostics



### Observe and Obey:

- ☑ Troubleshooting and repair procedures shall be completed by a person trained and qualified on the repair of this machine
- ☑ Immediately tag and remove from service a damaged or malfunctioning machine.
- ☑ Repair any machine damage or malfunction before operating the machine.
- ☑ Unless otherwise specified, perform each repair procedure with the machine in the following configuration:
  - Machine parked on a firm, level surface
  - Platform in the stowed position
  - Key switch in the off position with the key removed
  - The red Emergency Stop button in the off position at both ground and platform controls
  - Wheels chocked
  - All external AC power supply disconnected from the machine

### Before Troubleshooting:

- ☑ Read, understand and obey the safety rules and operating instructions in the appropriate operator's manual on your machine.
- ☑ Be sure that all necessary tools and test equipment are available and ready for use.
- ☑ Read each appropriate fault code thoroughly. Attempting short cuts may produce hazardous conditions.
- ☑ Be aware of the following hazards and follow generally accepted safe workshop practices.

**⚠ DANGER** Crushing hazard. When testing or replacing any hydraulic component, always support the structure and secure it from movement

**⚠ WARNING** Electrocutation/burn hazard. Contact with electrically charged circuits could result in death or serious injury. Remove all rings, watches and other jewelry.

**⚠ WARNING** Bodily injury hazard. Spraying hydraulic oil can penetrate and burn skin. Loosen hydraulic connections very slowly to allow the oil pressure to dissipate gradually. Do not allow oil to squirt or spray.

### About This Section

When a malfunction is discovered, the fault code charts in this section will help a service professional pinpoint the cause of the problem. To use this section, basic hand tools and certain pieces of test equipment are required — voltmeter, ohmmeter, pressure gauges.

# Diagnostics

## Definitions

GSDS – Genie SmartLink™ Diagnostic System

ECM – Electronic Control Module

GCON – Ground Controls

PCON – Platform Controls

OIC – Operational Indicator Codes

DTC – Diagnostic Trouble Codes

## GCON LCD Diagnostic Readout

**H001: COILFAULT  
PLAT UP1:Bat-**

The diagnostic readout displays alpha numeric codes that provide information about the machine operating status and about malfunctions.

The codes listed in the Diagnostic Trouble Code Charts describe malfunctions and can aid in troubleshooting the machine by pinpointing the area or component affected.

Models are listed below each code to assist in the troubleshooting codes for a specific model.

## Genie SmartLink Diagnostic System

This machine is equipped with the Genie SmartLink™ Diagnostic System (GSDS). The GSDS indicates a machine malfunction has happened by displaying Operational Indicator Codes (OIC) and Diagnostic Trouble Codes (DTC). These codes are displayed at the Platform Controls and the Ground Controls. The Ground Controls will display a brief description of the code at the LCD display as well. Refer to the GCON I/O Maps, Operational Indicator Codes (OIC) and Diagnostic Trouble Codes (DTC) in this section, to assist in troubleshooting faults.

## GCON ECM Connector Layout

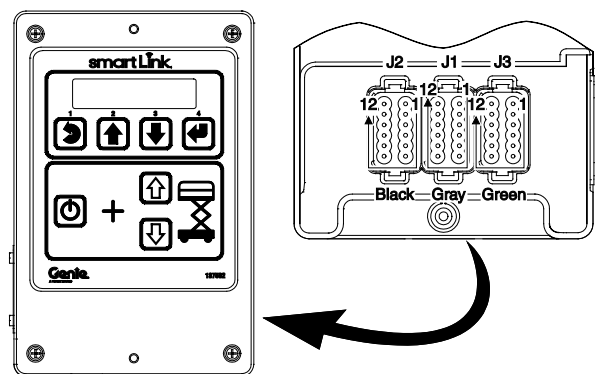

Rear of Ground Controls

# Diagnostics

<b>GCON I/O Map without Load Sense</b>			
<b>GCON Pin Number</b>	<b>Circuit Function</b>	<b>I/O Type</b>	<b>Wire Gauge and Color</b>
<b>J1 Connector – Gray</b>			
J1-01	ECM Power	Power Input	14 RD
J1-02	PCON, E-Stop Power	Power Output	18 RD
J1-03	PCON, E-Stop Return	Power Input	18 WH
J1-04	Link to PCON — CANH	Data Bus	18 GR
J1-05	Link to PCON — CANL	Data Bus	18 OR
J1-06	PCON — Ground	Ground Output	18 BR
J1-07	GCON — Ground	Ground Input	14 BR
J1-08	Key Switch — PCON Mode	Digital Input	18 BK
J1-09	Key Switch — GCON Mode	Digital Input	18 WH
J1-10	GCON — Emergency Mode	Digital Input	18 WH/BK
J1-11	No Circuit	N/A	N/A
J1-12	Driver Power	Power Input	14 RD
<b>J-2 Connector – Black</b>			
J2-01	Platform Up Coil	Digital Output	18 OR
J2-02	Platform Down Coil	Digital Output	18 OR/BK
J2-03	Steer Left Coil	Digital Output	18 BL/BK
J2-04	Steer Right Coil	Digital Output	18 BL
J2-05	Parallel Coil (not connected)	Digital Output	18 RD/WH
J2-06	Drive Forward Coil	Digital Output	18 WH
J2-07	No Circuit	N/A	N/A
J2-08	Motor Controller Enable	Digital Output	18 GR/WH
J2-09	No Circuit	N/A	N/A
J2-10	Drive Reverse Coil	Digital Output	18 WH/BK
J2-11	Motor Controller Throttle	Analog Output	18 GR
J2-12	No Circuit	N/A	N/A
<b>J-3 Connector – Green</b>			
J3-01	No Circuit	N/A	N/A
J3-02	GCON — Alarm	Digital Output	18 BL
J3-03	Switch/Sensor Power	Digital Output	14 RD
J3-04	Automotive Horn	Digital Output	18 WH
J3-05	Pothole Limit Switch	Digital Input	18 OR/RD
J3-06	Ground	Ground Input	18 BR
J3-07	Down Limit Switch	Digital Input	18 OR
J3-08	Level Sensor	Digital Input	18 RD/BK
J3-09	Ground	Ground Input	18 BK
J3-10	Ground	Ground Input	18 BK
J3-11	No Circuit	N/A	N/A
J3-12	Load Sense — Ground	Ground Input	18 BK

## Diagnostics

GCON I/O Map with Load Sense			
GCON Pin Number	Circuit Function	I/O Type	Wire Gauge and Color
<b>J1 Connector – Gray</b>			
J1-01	ECM Power	Power Input	14 RD
J1-02	PCON, E-Stop Power	Power Output	18 RD
J1-03	PCON, E-Stop Return	Power Input	18 WH
J1-04	Link to PCON — CANH	Data Bus	18 GR
J1-05	Link to PCON — CANL	Data Bus	18 OR
J1-06	PCON — Ground	Ground Output	18 BR
J1-07	GCON — Ground	Ground Input	14 BR
J1-08	Key Switch — PCON Mode	Digital Input	18 BK
J1-09	Key Switch — GCON Mode	Digital Input	18 WH
J1-10	GCON — Emergency Mode	Digital Input	18 WH/BK
J1-11	No Circuit	N/A	N/A
J1-12	Driver Power	Power Input	14 RD
<b>J-2 Connector – Black</b>			
J2-01	Platform Up Coil	Digital Output	18 OR
J2-02	Platform Down Coil	Digital Output	18 OR/BK
J2-03	Steer Left Coil	Digital Output	18 BL/BK
J2-04	Steer Right Coil	Digital Output	18 BL
J2-05	Parallel Coil (not connected)	Digital Output	18 RD/WH
J2-06	Drive Forward Coil	Digital Output	18 WH
J2-07	No Circuit	N/A	N/A
J2-08	Motor Controller Enable	Digital Output	18 GR/WH
J2-09	No Circuit	N/A	N/A
J2-10	Drive Reverse Coil	Digital Output	18 WH/BK
J2-11	Motor Controller Throttle	Analog Output	18 GR
J2-12	No Circuit	N/A	N/A
<b>J-3 Connector – Green</b>			
J3-01	No Circuit	N/A	N/A
J3-02	GCON — Alarm	Digital Output	18 BL
J3-03	Switch/Sensor Power	Digital Output	14 RD
J3-04	Automotive Horn	Digital Output	18 WH
J3-05	Pothole Limit Switch	Digital Input	18 OR/RD
J3-06	Ground	Ground Input	18 BR
J3-07	Down Limit Switch	Digital Input	18 OR
J3-08	Level Sensor	Digital Input	18 RD/BK
J3-09	Platform Overload Pressure Transducer	Ground Input	18 BL/WH
J3-10	Platform Height Sensor	Ground Input	18 OR/WH
J3-11	No Circuit	N/A	N/A
J3-12	Load Sense — Ground	Ground Input	18 BK

## Diagnostics

### Operational Indicator Codes (OIC)

These codes are generated by the electrical system to indicate machine operating status. During normal operation a code will appear in the platform controls LED readout if a condition such as off-level, overload cutout, chassis mode operation or pothole guards stuck occurs. These codes are not indicators of a device malfunction in the electrical system.

Code	Condition
LL	Off-Level
OL	Platform Overload (CE and Australia)
CH	Chassis Mode Operation
PHS	Pothole Guard Stuck
OAC	Obstruction Above Chassis (QSR only)

### Diagnostic Trouble Codes (DTC)

These codes are generated by the system to indicate that a device or circuit malfunction has been detected in the electrical system. The types of Diagnostic Trouble Codes that may occur are explained below.

Type "HXXX" – Indicate a malfunction associated with devices that control hydraulic functions in the electrical system. The "HXXX" faults are divided into short circuit battery negative, short circuit to battery positive, open circuit and generic shorts. Examples of these devices are solenoid controlled hydraulic valves and motor controller.

Type "PXXX" – Indicate a malfunction associated with power type devices in the electrical system. The "PXXX" faults are divided into short circuit to battery negative, short circuit to battery positive, open circuit and generic shorts. Examples of these devices are horns, sensor power and alarms.

Type "UXXX" – Indicate a malfunction associated with user interface devices in the electrical system. The "UXXX" faults are divided into short circuit to battery negative, short circuit to battery positive, open circuit and generic shorts. Examples of these devices are GCON up and down switches and PCON drive joystick.

Type "FXXX" – Indicate a malfunction associated with machine feedback devices in the electrical system. The "FXXX" faults are divided into short circuit to battery negative, short circuit to battery positive, open circuit and generic shorts. Examples of these devices are limit switches, height sensors and pressure transducers.

Type "CXXX" – Indicate a malfunction associated with controls devices in the electrical system. Examples of these devices are platform controls and ground controls ECM.

# Diagnostics

## Troubleshooting "HXXX" and "PXXX" Faults

The procedure below illustrates typical steps for diagnosing and fixing faults of type "HXXX" and "PXXX".

### Diagnostic Chart

1	Check the faulted device for a short or open circuit.	No <b>Good</b> →	Replace faulted device.
<b>Good ↓</b>			
2	Check short or open circuit of the harness or connector between Ground Controls and faulted device.	No <b>Good</b> →	Repair or replace harness an/or connector.
<b>Good ↓</b>			
3	Check GCON Electronic Control Module (ECM).	No <b>Good</b> →	Replace ECM.

### Wiring Diagram

The wiring diagram shown below illustrates how fault type "HXXX" and "PXXX" devices are typically wired. The signal of these types of devices originates at the Ground Controls and terminates at system ground.

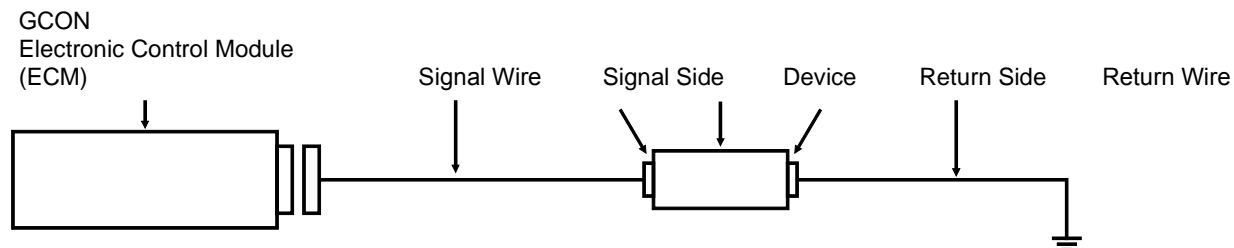

In order to successfully troubleshoot "HXXX" or "PXXX" type faults, the entire faulted out circuit must be investigated.

# Diagnosics

## Fault Inspection Procedure

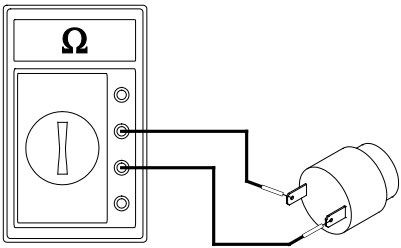
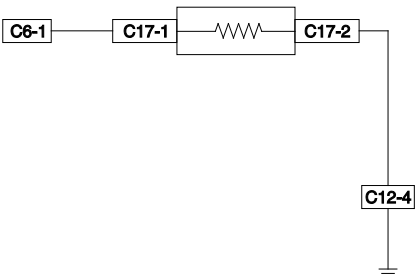
<b>1</b>	<b>Check the device associated with the faulted circuit</b>																		
	<ol style="list-style-type: none"> <li>1 Disconnect the faulted device connector.</li> <li>2 Using a multi-meter, measure resistance between the two terminals of the faulted device.</li> <li>3 Resistance should be as follows.</li> </ol> <table border="0" style="width: 100%;"> <thead> <tr> <th style="text-align: left;">Device</th> <th style="text-align: right;">Typical Resistance</th> </tr> </thead> <tbody> <tr> <td>Solenoid Valve, Drive</td> <td style="text-align: right;">27.2 Ω</td> </tr> <tr> <td>Solenoid Valve, Steer</td> <td style="text-align: right;">19 Ω</td> </tr> <tr> <td>Solenoid Valve, Platform Up</td> <td style="text-align: right;">25 Ω</td> </tr> <tr> <td>Solenoid Valve, Platform Down</td> <td style="text-align: right;">6.25 Ω</td> </tr> <tr> <td>GCON and PCON Alarm</td> <td style="text-align: right;">&gt;1M Ω</td> </tr> <tr> <td>Automotive Horn</td> <td style="text-align: right;">1.0 Ω</td> </tr> <tr> <td>Contacting Coil</td> <td style="text-align: right;">47 Ω</td> </tr> </tbody> </table>			Device	Typical Resistance	Solenoid Valve, Drive	27.2 Ω	Solenoid Valve, Steer	19 Ω	Solenoid Valve, Platform Up	25 Ω	Solenoid Valve, Platform Down	6.25 Ω	GCON and PCON Alarm	>1M Ω	Automotive Horn	1.0 Ω	Contacting Coil	47 Ω
	Device	Typical Resistance																	
Solenoid Valve, Drive	27.2 Ω																		
Solenoid Valve, Steer	19 Ω																		
Solenoid Valve, Platform Up	25 Ω																		
Solenoid Valve, Platform Down	6.25 Ω																		
GCON and PCON Alarm	>1M Ω																		
Automotive Horn	1.0 Ω																		
Contacting Coil	47 Ω																		
<b>OK</b>	<b>Go to step 2</b>	No Good	<b>Replace faulted device</b>																
<b>2</b>	<b>Check the harness between the ground controls and the faulted device</b>																		
	<ol style="list-style-type: none"> <li>1 Disconnect the GCON ECM connectors, C1, C2 and C3. (or C4 if equipped with outriggers).</li> <li>2 Disconnect the faulted device connector.</li> <li>3 Check the continuity between the GCON ECM connector and the signal side of the faulted device.                             <ul style="list-style-type: none"> <li>⊙ Result: Resistance should be close to 0 Ω.</li> </ul> </li> <li>4 Check the continuity between the return side of faulted device and system ground.                             <ul style="list-style-type: none"> <li>⊙ Result: Resistance should be close to 0 Ω.</li> </ul> </li> <li>5 Check resistance between return side and signal side of the harness plug of faulted device.                             <ul style="list-style-type: none"> <li>⊙ Result: Resistance should be 1M Ω or higher.</li> </ul> </li> </ol>																		
	<b>OK</b>	<b>Go to step 3</b>	No Good	<b>Replace or repair harness</b>															
<b>3</b>	<b>Check the GCON ECM</b>																		

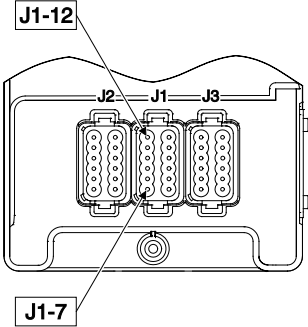

## Diagnostics

 <p>The diagram shows three multi-pin connectors labeled J1, J2, and J3. Pin J1-7 is indicated as ground and pin J1-12 is indicated as driver power.</p>	<ol style="list-style-type: none"> <li>1 Disconnect the GCON ECM connectors, C1, C2 and C3. (or C4 if equipped with outriggers).</li> <li>2 For short to B- type faults, measure resistance between pins J1-7 (ground) and the GCON pin associated with the fault code. Refer to the GCON I/O Map in this section to identify the faulted out circuit pin.</li> <li>3 Short to ground resistance should be greater than 5k <math>\Omega</math>.</li> <li>4 For short to B+ type faults, measure resistance between pins J1-12 (driver power) and the GCON pin associated with the fault code. Refer to the GCON I/O Map in this section to identify the faulted out circuit pin.</li> <li>5 Short to power resistance should be greater than 50k <math>\Omega</math>.</li> </ol>
No Good	<b>Replace GCON ECM</b>

# Diagnostics

## Type "HXXX" Faults

DTC Number	Message on GCON LCD	Description	Possible Causes	Failure Mode
H001:	H001:COILFAULT PLAT UP1:BAT-	Short circuit of the platform up #1 circuit to battery negative.	<ul style="list-style-type: none"> <li>• Short circuit in platform up #1 harness.</li> <li>• Platform up #1 coil short circuit.</li> <li>• GCON ECM.</li> </ul>	Platform up function inhibited.
H002:	H002:COILFAULT PLAT UP1:OPEN	Open circuit in the platform up #1 circuit.	<ul style="list-style-type: none"> <li>• Short circuit in platform up #1 harness.</li> <li>• Platform up #1 coil open circuit.</li> <li>• GCON ECM.</li> </ul>	Platform up function inhibited.
H003:	H003:COILFAULT PLAT UP1:BAT+	Short circuit of the platform up #1 circuit to battery positive.	<ul style="list-style-type: none"> <li>• Short circuit in platform up #1 harness.</li> <li>• Platform up #1 coil short circuit.</li> <li>• GCON ECM.</li> </ul>	All functions inhibited except platform down.
H009:	H009:COILFAULT PLAT DOWN1:BAT+	Short circuit of the platform down #1 circuit to battery positive.	<ul style="list-style-type: none"> <li>• Short circuit in platform down #1 harness.</li> <li>• Platform down #1 coil short circuit.</li> <li>• GCON ECM.</li> </ul>	All functions inhibited.
H013:	H013:COILFAULT DRIVE FWD1:BAT-	Short circuit of the drive forward #1 circuit to battery negative.	<ul style="list-style-type: none"> <li>• Short circuit in drive forward #1 harness.</li> <li>• Drive forward #1 coil short circuit.</li> <li>• GCON ECM.</li> </ul>	Drive forward function inhibited.
H014:	H014:COILFAULT DRIVE FWD1:OPEN	Open circuit in the drive forward #1 circuit.	<ul style="list-style-type: none"> <li>• Open circuit in drive forward #1 harness.</li> <li>• Drive forward #1 coil open circuit.</li> <li>• GCON ECM.</li> </ul>	Drive forward function inhibited.
H015:	H015:COILFAULT DRIVE FWD1:BAT+	Short circuit of the drive forward #1 circuit to battery positive.	<ul style="list-style-type: none"> <li>• Short circuit in drive forward #1 harness.</li> <li>• Drive forward #1 coil short circuit.</li> <li>• GCON ECM.</li> </ul>	All functions inhibited except platform down.
H019:	H019:COILFAULT DRIVE REV1:BAT-	Short circuit of the drive reverse #1 circuit to battery negative.	<ul style="list-style-type: none"> <li>• Short circuit in drive reverse #1 harness.</li> <li>• Drive reverse #1 coil short circuit.</li> <li>• GCON ECM.</li> </ul>	Drive reverse function inhibited.
H020:	H020:COILFAULT DRIVE REV1:OPEN	Open circuit in the drive reverse #1 circuit.	<ul style="list-style-type: none"> <li>• Open circuit in drive reverse #1 harness.</li> <li>• Drive reverse #1 coil open circuit.</li> <li>• GCON ECM.</li> </ul>	Drive reverse function inhibited.
H021:	H021:COILFAULT DRIVE REV1:BAT+	Short circuit of the drive reverse #1 circuit to battery positive.	<ul style="list-style-type: none"> <li>• Short circuit in drive reverse #1 harness.</li> <li>• Drive reverse #1 coil short circuit.</li> <li>• GCON ECM.</li> </ul>	All functions inhibited except platform down.
H027:	H027:COILFAULT DRIVE STEER RIGHT:BAT+	Short circuit of the steer right circuit to battery positive.	<ul style="list-style-type: none"> <li>• Short circuit in steer right harness.</li> <li>• Steer right coil short circuit.</li> <li>• GCON ECM.</li> </ul>	All functions inhibited except platform down.
H030:	H030:COILFAULT DRIVE STEER LEFT:BAT+	Short circuit of the steer left circuit to battery positive.	<ul style="list-style-type: none"> <li>• Short circuit in steer left harness.</li> <li>• Steer left coil short circuit.</li> <li>• GCON ECM.</li> </ul>	All functions inhibited except platform down.
H067:	H067:FAULT MC ENABLE:BAT-	Short circuit of the motor controller circuit to battery negative.	<ul style="list-style-type: none"> <li>• Short circuit in motor controller enable wire.</li> <li>• Motor Controller.</li> <li>• Contactor coil shorted to battery negative.</li> <li>• GCON ECM.</li> </ul>	All functions inhibited except platform down.
H069:	H069:FAULT MC ENABLE:BAT+	Short circuit of the motor controller circuit to battery positive.	<ul style="list-style-type: none"> <li>• Short circuit in motor controller enable wire.</li> <li>• Motor Controller.</li> <li>• Contactor Coil.</li> <li>• GCON ECM.</li> </ul>	All functions inhibited except platform down.
H070:	H070:FAULT MC THROTTLE:BAT-	Short circuit of the motor controller throttle circuit to battery negative.	<ul style="list-style-type: none"> <li>• Short circuit in motor controller throttle wire.</li> <li>• Motor Controller.</li> <li>• GCON ECM.</li> </ul>	All functions inhibited except platform down.
H072:	H072:FAULT MC THROTTLE:BAT+	Short circuit of the motor controller throttle circuit to battery positive.	<ul style="list-style-type: none"> <li>• Short circuit in motor controller throttle wire.</li> <li>• Motor Controller.</li> <li>• GCON ECM.</li> </ul>	All functions inhibited except platform down.
H078:	H078:COILFAULT PLAT DOWN1	Short circuit of the platform down #1 circuit to battery positive/negative or open circuit.	<ul style="list-style-type: none"> <li>• Short or open circuit in platform down #1 harness.</li> <li>• Platform down #1 coil short or open circuit.</li> <li>• GCON ECM.</li> </ul>	Platform down function inhibited.
H080:	H080:COILFAULT STEER LEFT	Short circuit of the steer left circuit to battery negative or open circuit.	<ul style="list-style-type: none"> <li>• Short or open circuit in steer left harness.</li> <li>• Steer left coil short or open circuit.</li> <li>• GCON ECM.</li> </ul>	Steer left function inhibited.
H081:	H081:COILFAULT STEER RIGHT	Short circuit of the steer right circuit to battery negative or open circuit.	<ul style="list-style-type: none"> <li>• Short or open circuit in steer right harness.</li> <li>• Steer right coil short or open circuit.</li> <li>• GCON ECM.</li> </ul>	All functions inhibited except platform down while above limit switch.

## Diagnostics

### Type "PXXX" Faults

DTC Number	Message on GCON LCD	Description	Possible Causes	Failure Mode
<b>P001:</b>	P001:PWR FAULT SW PWR1:BAT-	Short circuit of the switched power #1 circuit to battery negative.	<ul style="list-style-type: none"> <li>• Short circuit in switched power #1, down limit switch, pothole limit switch, digital tilt switch harness.</li> <li>• GCON ECM.</li> </ul>	All functions inhibited.
<b>P003:</b>	P003:PWR FAULT SW PWR1:BAT+	Short circuit of the switched power #1 circuit to battery positive.	<ul style="list-style-type: none"> <li>• Short circuit in switched power #1, down limit switch, pothole limit switch, digital tilt switch harness.</li> <li>• GCON ECM.</li> </ul>	All functions inhibited.
<b>P004:</b>	P004:DEVICEFAULT HORN:BAT-	Short circuit of the automotive horn circuit to battery negative.	<ul style="list-style-type: none"> <li>• Short circuit in automotive horn harness.</li> <li>• Automotive horn short circuit.</li> <li>• GCON ECM.</li> </ul>	Automotive horn inhibited.
<b>P005:</b>	P005:DEVICEFAULT HORN:OPEN	Open circuit of the automotive horn circuit.	<ul style="list-style-type: none"> <li>• Open circuit in automotive horn harness.</li> <li>• Automotive horn open circuit.</li> <li>• GCON ECM.</li> </ul>	Automotive horn inhibited.
<b>P006:</b>	P006:DEVICEFAULT HORN:BAT+	Short circuit of the automotive horn circuit to battery positive.	<ul style="list-style-type: none"> <li>• Short circuit in automotive horn harness.</li> <li>• Automotive horn short circuit.</li> <li>• GCON ECM.</li> </ul>	Automotive horn inhibited.
<b>P007:</b>	P007:DEVICEFAULT GCON ALARM:BAT-	Short circuit of the GCON alarm circuit to battery negative.	<ul style="list-style-type: none"> <li>• Short circuit in GCON alarm harness.</li> <li>• GCON alarm short circuit.</li> <li>• GCON ECM.</li> </ul>	GCON alarm inhibited.
<b>P009:</b>	P009:DEVICEFAULT GCON ALARM:BAT+	Short circuit of the GCON alarm circuit to battery positive.	<ul style="list-style-type: none"> <li>• Short circuit in GCON alarm harness.</li> <li>• GCON alarm short circuit.</li> <li>• GCON ECM.</li> </ul>	GCON alarm inhibited.
<b>P013:</b>	P013:PWR FAULT PCON PWRET:BAT-	Short circuit of the PCON power return circuit to battery negative.	<ul style="list-style-type: none"> <li>• Short circuit in PCON power return harness.</li> <li>• GCON ECM.</li> </ul>	All functions inhibited.
<b>P015:</b>	P015:PWR FAULT PCON PWRET:BAT+	Short circuit of the PCON power return circuit to battery positive.	<ul style="list-style-type: none"> <li>• Short circuit in PCON power return harness.</li> <li>• GCON ECM.</li> </ul>	All functions inhibited.
<b>P018:</b>	018:PWR FAULT PCON POWER:BAT-	Short circuit of the PCON power circuit to battery negative.	<ul style="list-style-type: none"> <li>• Short circuit in PCON power harness.</li> <li>• GCON ECM.</li> </ul>	All functions inhibited.
<b>P019:</b>	018:PWR FAULT PCON POWER:BAT+	Short circuit of the PCON power circuit to battery positive.	<ul style="list-style-type: none"> <li>• Short circuit in PCON power harness.</li> <li>• GCON ECM.</li> </ul>	All functions inhibited.

# Diagnostics

## Type "UXXX" Faults

DTC Number	Message on GCON LCD	Description	Possible Causes	Failure Mode
U001:	U001:SWITCHFAULT GCON MAIN FTM EN	Short circuit of the GCON main function enable switch at system startup.	<ul style="list-style-type: none"> <li>Short circuit of the GCON main function enable switch.</li> <li>GCON ECM.</li> </ul>	All GCON functions inhibited.
U002:	U002:SWITCHFAULT GCON PLAT UP	Short circuit of the GCON up directional switch at system startup.	<ul style="list-style-type: none"> <li>Short circuit of the GCON up directional switch.</li> <li>GCON ECM.</li> </ul>	All GCON functions inhibited except platform down.
U003:	U003:SWITCHFAULT GCON PLAT DOWN	Short circuit of the GCON down directional switch at system startup.	<ul style="list-style-type: none"> <li>Short circuit of the GCON down directional switch.</li> <li>GCON ECM.</li> </ul>	All GCON functions inhibited except platform up.
U004:	U004:SWITCHFAULT GCON LCD UP	Short circuit of the GCON LCD scroll up switch at system startup.	<ul style="list-style-type: none"> <li>Short circuit of the GCON LCD scroll up switch.</li> <li>GCON ECM.</li> </ul>	All GCON LCD menu functions inhibited.
U005:	U005:SWITCHFAULT GCON LCD DOWN	Short circuit of the GCON LCD scroll down switch at system startup.	<ul style="list-style-type: none"> <li>Short circuit of the GCON LCD scroll down switch.</li> <li>GCON ECM.</li> </ul>	All GCON LCD menu functions inhibited.
U006:	U006:SWITCHFAULT GCON LCD ENTER	Short circuit of the GCON LCD enter switch at system startup.	<ul style="list-style-type: none"> <li>Short circuit of the GCON LCD enter switch.</li> <li>GCON ECM.</li> </ul>	All GCON LCD menu functions inhibited.
U007:	U007:SWITCHFAULT GCON LCD ESCAPE	Short circuit of the GCON LCD escape switch at system startup.	<ul style="list-style-type: none"> <li>Short circuit of the GCON LCD escape switch.</li> <li>GCON ECM.</li> </ul>	All GCON LCD menu functions inhibited.
U015:	U015:SWITCHFAULT PCON STEER LEFT	Short circuit of the PCON steer left switch at system startup.	<ul style="list-style-type: none"> <li>Short circuit of the PCON steer left switch.</li> <li>GCON ECM.</li> </ul>	All PCON drive and steer functions inhibited.
U016:	U016:SWITCHFAULT PCON STEER RIGHT	Short circuit of the PCON steer right switch at system startup.	<ul style="list-style-type: none"> <li>Short circuit of the PCON steer right switch.</li> <li>GCON ECM.</li> </ul>	All PCON drive and steer functions inhibited.
U017:	U017:SWITCHFAULT PCON HORN	Short circuit of the PCON horn switch at system startup.	<ul style="list-style-type: none"> <li>Short circuit of the PCON horn switch.</li> <li>GCON ECM.</li> </ul>	PCON horn switch function inhibited.
U018:	U018:SWITCHFAULT PCON LO DRIV SPD	Short circuit of the PCON low drive speed switch at system startup.	<ul style="list-style-type: none"> <li>Short circuit of the PCON low drive speed switch.</li> <li>GCON ECM.</li> </ul>	The machine is limited to low drive speed.
U033:	U033:JSTICKFAULT OUT OF CAL RANGE	PCON drive joystick signal is outside acceptable calibration range at system startup.	<ul style="list-style-type: none"> <li>PCON drive joystick is not in neutral position at startup.</li> <li>PCON joystick.</li> <li>GCON ECM.</li> </ul>	All PCON drive and steer functions inhibited.
U034:	U034:JSTICKFAULT OUT OF RANGE:HI	Short circuit of the PCON drive joystick signal to battery positive at system startup.	<ul style="list-style-type: none"> <li>Short circuit of the PCON drive joystick signal circuit.</li> <li>PCON joystick.</li> <li>GCON ECM.</li> </ul>	All PCON drive and steer functions inhibited.
U035:	U035:JSTICKFAULT OUT OF RANGE:LO	Short circuit of the PCON drive joystick signal to battery negative at system startup.	<ul style="list-style-type: none"> <li>Short circuit of the PCON drive joystick signal circuit.</li> <li>PCON joystick.</li> <li>GCON ECM.</li> </ul>	All PCON drive and steer functions inhibited.
U036:	U036:SWITCHFAULT GCON + PCON:ON	Mis-wiring or short circuit of GCON key switch.	<ul style="list-style-type: none"> <li>Short circuit of the PCON drive enable switch.</li> <li>GCON ECM.</li> </ul>	All functions inhibited.
U042:	U042:SWITCHFAULT PCON DRIVE MODE	PCON drive mode switch stuck closed, or depressed prior to startup.	<ul style="list-style-type: none"> <li>Drive mode switch stuck closed.</li> <li>Drive mode switch is depressed at system startup.</li> <li>PCON ECM.</li> </ul>	Drive functions inhibited.
U045:	U045:SWITCHFAULT PCON DRIVE EN	Short circuit of the PCON drive enable switch at system startup.	<ul style="list-style-type: none"> <li>Short circuit of the PCON drive enable switch.</li> <li>PCON ECM.</li> <li>GCON ECM.</li> </ul>	All drive and steer functions inhibited.
U046:	U046:SWITCHFAULT PCON LIFT MODE	PCON function enable switch stuck closed, or depressed at system startup.	<ul style="list-style-type: none"> <li>PCON lift mode switch depressed at system startup.</li> <li>PCON ECM.</li> </ul>	All functions operate except platform up/down.

## Diagnostics

### Type "FXXX" Faults

DTC Number	Message on GCON LCD	Description	Possible Causes	Failure Mode
<b>F001:</b>	F001:SWITCHFAULT UP LIMIT1:BAT+	Short circuit of the up limit #1 switch at system startup.	<ul style="list-style-type: none"> <li>• Short circuit of the up limit switch circuit.</li> <li>• Up limit #1 switch short circuit.</li> <li>• GCON ECM.</li> </ul>	Platform up function inhibited.
<b>F003:</b>	F003:SWITCHFAULT DOWN LIMIT1:BAT+	Short circuit of the down limit #1 switch at system startup.	<ul style="list-style-type: none"> <li>• Short circuit of the down limit switch circuit.</li> <li>• Down limit #1 switch short circuit.</li> <li>• GCON ECM.</li> </ul>	All functions inhibited except platform down.
<b>F005:</b>	F005:SWITCHFAULT POTHOLE:BAT+	Short circuit of the pothole limit #1 switch at system startup.	<ul style="list-style-type: none"> <li>• Short circuit of the pothole switch circuit.</li> <li>• Pothole limit #1 switch short circuit.</li> <li>• GCON ECM.</li> </ul>	All functions inhibited except platform down as long as machine is in the elevated position. If machine is in stowed position, all functionality is resumed.
<b>F007:</b>	F007:SWITCHFAULT CHASSISTILT:BAT+	Short circuit of the chassis digital tilt switch at system startup.	<ul style="list-style-type: none"> <li>• Short circuit of the chassis digital tilt switch circuit.</li> <li>• Chassis digital tilt switch short circuit.</li> <li>• GCON ECM.</li> </ul>	All functions inhibited except platform down as long as machine is in the elevated position. If machine is in stowed position, all functionality is resumed.
F031:	F031:SWITCHFAULT OAC SWITCH:Bat+	Short circuit of obstruction sensing circuit to battery positive.	<ul style="list-style-type: none"> <li>• Short circuit in the obstruction sensing harness.</li> <li>• GCON ECM.</li> </ul>	All functions inhibited.
F032:	F032:SWITCHFAULT OVLN SWITCH:Bat+	Short circuit of pressure switch to battery positive.	<ul style="list-style-type: none"> <li>• Short circuit in the limit switch harness.</li> <li>• GCON ECM.</li> </ul>	All functions inhibited.
F033:	F033:SWITCHFAULT OVLN:Open/Bat-	Open or short circuit of pressure switch.	<ul style="list-style-type: none"> <li>• Open or short circuit in the limit switch harness.</li> <li>• GCON ECM.</li> </ul>	All functions inhibited.
F072:	F072:SENSORFAULT FUNCTION CUT B+	Function Cutout sensor B+ fault.	<ul style="list-style-type: none"> <li>• Faulty extension deck limit switch.</li> <li>• Faulty gate proximity switch.</li> <li>• GCON ECM.</li> </ul>	All functions inhibited.

# Diagnostics

## Type "CXXX" Faults

DTC Number	Message on GCON LCD	Description	Possible Causes	Failure Mode
<b>C001:</b>	C001:GCON ECM FAULT TYPE 1	GCON ECM CRC check error.	<ul style="list-style-type: none"> <li>• Incorrect software file.</li> <li>• GCON ECM internal failure.</li> </ul>	All functions inhibited.
<b>C004:</b>	C004:GCON ECM FAULT TYPE 4	GCON ECM master switch error.	<ul style="list-style-type: none"> <li>• Short circuit in the master switch circuit.</li> <li>• GCON ECM.</li> </ul>	All functions inhibited.
<b>C005:</b>	C005:GCOM ECM FAULT TYPE 5	GCON ECM safety switch error.	<ul style="list-style-type: none"> <li>• Short circuit in the safety switch circuit.</li> <li>• GCON ECM.</li> </ul>	All functions inhibited.
<b>C006:</b>	C006:GCON ECM FAULT TYPE 6	GCON input redundancy error.	<ul style="list-style-type: none"> <li>• Input conditioning circuit failure.</li> <li>• GCON ECM.</li> </ul>	All functions inhibited.
<b>C007:</b>	C007:GCON ECM FAULT TYPE 7	GCON ECM inter-processor communication error.	<ul style="list-style-type: none"> <li>• Incorrectly programmed device.</li> <li>• Error in loading software on device.</li> <li>• GCON ECM.</li> </ul>	All functions inhibited.
<b>C009:</b>	C009:GCON ECM FAULT TYPE 9	GCON fault type 9.	<ul style="list-style-type: none"> <li>• Contact Genie support.</li> </ul>	All functions inhibited.
C010:	C010:SECONDARY NOT PROGRAMMED	GCON secondary processor not programmed.	<ul style="list-style-type: none"> <li>• Incorrectly programmed device.</li> <li>• Error in loading software on device.</li> <li>• GCON ECM.</li> </ul>	All functions inhibited.
<b>C021:</b>	C021:PCON NOT DETECTED	PCON not detected error.	<ul style="list-style-type: none"> <li>• PCON disconnected.</li> <li>• CAN communication failure.</li> <li>• GCON or PCON ECM.</li> </ul>	All functions inhibited.
<b>C023:</b>	C023:MACHINE MODEL FAULT	Discrepancy between model detected and model programmed.	<ul style="list-style-type: none"> <li>• Incorrect machine model programmed.</li> <li>• GCON or PCON ECM.</li> </ul>	All functions inhibited.
<b>C028:</b>	C028:SERVICE OVERRIDE MODE ON	Machine is in service override mode.	<ul style="list-style-type: none"> <li>• Machine programmed for use in service override mode.</li> </ul>	All functions inhibited except for down function and up function. Platform can be elevated only once with the maximum elevate time of XX seconds. Elevate time XX depends on machine model.
C053:	C053:PCON-GCON SOFTWARE MISMATCH	Software revisions do not match between the PCON and GCON.	<ul style="list-style-type: none"> <li>• C053 displayed at GCON, PCON with older software revision connected to GCON with newer software revision.</li> <li>• C053 displayed at PCON, PCON with newer software revision connected to GCON with older software revision.</li> </ul>	All functions inhibited.

---

# Diagnostics

## Battery Charger

The charger continuously monitors internal and external conditions. Fault and Error codes are generated by the charger to indicate that an internal or external malfunction has been detected in the electrical system. The types of Diagnostic Trouble Codes that may occur are explained below.

Type "F" codes – Indicate an internal fault condition has occurred and caused charging to stop.

Type "E" codes - Indicate an external fault condition has occurred and caused charging to stop.

Type "P" code - Indicates charger programming mode is active. This will occur when the charger profile is being configured.

Type "USB" code - Indicates the USB interface is active, and the USB should not be removed. This will occur when the charger firmware is being updated.



Solid red - Internal fault condition. Type "F" fault code.



Flashing amber - External fault condition. Type "E" error code.



Flashing green - USB interface is active.



Solid green - Firmware update is complete. Remove USB from charger.

Codes are displayed as F, E or P and followed by three numbers and a period (example: E-0-0-4). The charger can display multiple codes.

If the batteries are changed from one type to another, (example: flooded lead acid to AGM), the charger profile must be programmed. Refer to Repair Procedure, *Programming the Charger Profile*.

# Diagnostics

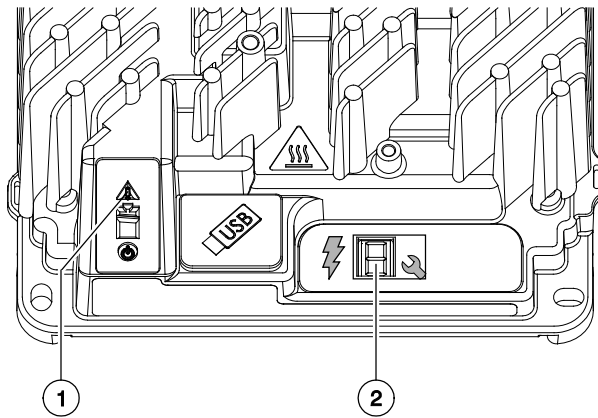

Charger status indicators

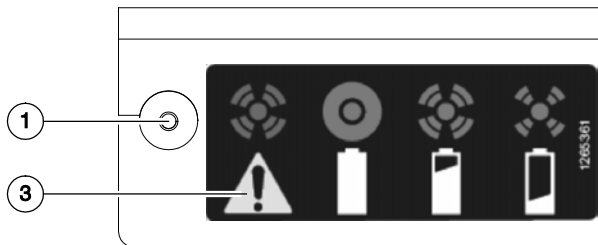

Remote charger status indicators

- 1 Error / Fault indicator
- 2 Charger display
- 3 Error / Fault

## Charger Fault Codes

Fault Code	Description	Possible Causes	Solution
F-0-0-1	DC-DC failure: LLC excessive leakage fault.	Internal charger fault.	Disconnect AC input and battery pack for 30 seconds. If fault does not clear, contact Genie Product Support.
F-0-0-2	PFC failure: PFC excessive leakage fault.		
F-0-0-3	PFC taken too long to boost.		
F-0-0-4	Charger unable to calibrate current offset.		
F-0-0-5	Output relay voltage too high when closed.		

## Diagnostics

### Charger Error Codes

Error Code	Description	Condition	Possible Causes
E-0-0-1	High battery voltage	Battery voltage too high to charge.	Check battery voltage and cable connections. Self clearing when condition has been corrected.
E-0-0-2	Low battery voltage detected prior to starting charge cycle	Battery voltage too low to charge.	Check battery voltage and cable connections. Check battery condition. Self clearing when condition has been corrected.
E-0-0-3	Charge timeout	Charge timeout caused by battery pack not reaching required voltage within safe time limit.	Charge output reduced due to high temperature. Charge at lower temperature. Check battery condition. Replace damaged battery. Check battery connections. Battery pack deep discharge. Disconnect battery pack for 30 seconds to clear fault when condition has been corrected.
E-0-0-4	Defective battery	Battery pack could not be trickle charged up to the minimum voltage.	Check battery condition. Replace damaged battery. Check battery connections. Disconnect battery pack for 30 seconds to clear fault when condition has been corrected.
E-0-0-7	Amp hour limit exceeded	Safety limit exceeded.	Check battery condition. Replace damaged battery. Check battery connections. Battery pack deep discharge. High parasitic loads on battery pack while charging. Disconnect parasitic loads. Disconnect battery pack for 30 seconds to clear fault when condition has been corrected.

## Diagnostics

### Charger Error Codes

Error Code	Description	Condition	Possible Causes
E-0-0-8	Battery temperature out of range	Battery temperature sensor.	Check temperature sensor and electrical connections. Rest charger. Disconnect AC power for 30 seconds. Self clearing when condition has been corrected.
E-0-1-1	Charger disabled by external command	Battery pack not being charged..	Power outage. AC power disconnected before charging complete.
E-0-1-2	Reverse polarity	Battery connected incorrectly.	Check battery connections. Self clearing when condition has been corrected.
E-0-1-3	Battery does not take current	Battery voltage is detected, but charger is unable to charge the battery pack..	Incorrect profile for battery type. Installed from a different machine with different battery type. Disconnect battery pack for 30 seconds to clear fault when condition has been corrected.
E-0-1-6	Software update failed	Software update failed.	Confirm USB Flash Drive is formatted with correct software. If software update continues to fail, contact Genie Product support.
E-0-1-7	USB error	USB not connected correctly.	Remove and re-insert USB Flash Drive. Disconnect AC input and battery pack for 30 seconds.
E-0-1-8	Slot CRC error	Software update failed.	Confirm USB Flash Drive is formatted with correct software. If software update continues to fail, contact Genie Product support.
E-0-1-9	Hardware does not support software	Charger hardware does not support software version being programmed.	Confirm USB Flash Drive is formatted with correct software. If software update continues to fail, contact Genie Product support.
E-0-2-0	No algorithm selected	Charger profile not programmed.	Program the charger for the proper battery profile.

## Diagnostics

### Charger Error Codes

Error Code	Description	Condition	Possible Causes
E-0-2-1	High battery voltage detected while charging	Battery voltage too high as detected by charger profile.	Check battery voltage and cable connections. Confirm charger profile is programmed for correct battery type. Self clearing when condition has been corrected.
E-0-2-2	Low battery voltage detected while charging	Battery voltage too low as detected by charger profile.	Check battery voltage and cable connections. Confirm charger profile is programmed for correct battery type. Self clearing when condition has been corrected.
E-0-2-3	High AC voltage	AC voltage greater than 270 VAC.	Connect to a stable AC source between 85 - 270 VAC / 45 - 65 Hz. Self clearing when condition has been corrected.
E-0-2-4	Failure to initialize	Charger failed to turn on correctly.	Disconnect AC input and battery pack for 30 seconds. Contact Genie Product Support.
E-0-2-5	Low AC voltage oscillation	AC voltage unstable.	Connect to a stable AC source between 85 - 270 VAC / 45 - 65 Hz. Using an undersized generator. Self clearing when condition has been corrected.
E-0-2-6	Script failure	Software update failed.	Confirm USB Flash Drive is formatted with correct software. If software update continues to fail, contact Genie Product support.
E-0-2-7	USB over current fault	USB over current protection has been tripped.	Remove and re-insert USB Flash Drive. Use different USB Flash drive.
E-0-2-8	Charge profile incompatibility	Selected charger profile is not compatible with charger software.	Update charger software. Confirm charger profile is programmed for correctly. Updating current firmware and error occurs, contact Genie Product Support.

## Diagnosics

### Charger Error Codes

Error Code	Description	Condition	Possible Causes
E-0-2-9	CAN Bus error	CAN Bus network error.	Check CAN Bus connections. CAN modules not functioning correctly. Termination resistance is ~60 ohms.
E-0-3-0	COMM battery module error	CAN Bus battery module error.	CAN Buss battery module not functioning correctly.
E-0-3-1	Vref for ADC measurements triggered alarm	Internal charger error.	Disconnect AC input and battery pack for 30 seconds. Contact Genie Product Support.
E-0-3-2	CAN Bus heartbeat error	CAN Bus heartbeat error.	CAN Bus devices not functioning correctly.
E-0-3-6	Battery temperature sensor charge profile	Battery temperature sensor is required by charger profile but is not installed.	Check battery temperature sensor connections. Check charger profile and confirm battery temperature sensor is installed.
E-0-3-8	CAN Open Error	CAN Open reprogramming failed.	Download CAN Open software. Reprogram charger using USB Flash Drive.

This page intentionally left blank.

## Schematics



### Observe and Obey:

- ☑ Troubleshooting and repair procedures shall be completed by a person trained and qualified on the repair of this machine
- ☑ Immediately tag and remove from service a damaged or malfunctioning machine.
- ☑ Repair any machine damage or malfunction before operating the machine.

### Before Troubleshooting:

- ☑ Read, understand and obey the safety rules and operating instructions in the appropriate operator's manual on your machine.
- ☑ Be sure that all necessary tools and test equipment are available and ready for use.

### About This Section

There are two groups of schematics in this section.

#### Electrical Schematics

**⚠ WARNING**

Electrocution/burn hazard. Contact with electrically charged circuits could result in death or serious injury. Remove all rings, watches and other jewelry.

#### Hydraulic Schematics

**⚠ WARNING**

Bodily injury hazard. Spraying hydraulic oil can penetrate and burn skin. Loosen hydraulic connections very slowly to allow the oil pressure to dissipate gradually. Do not allow oil to squirt or spray.

## Electrical Component and Wire Color Legends

ELECTRICAL COMPONENT LEGEND	
Item	Description
B1 - B4	Battery, 6V DC
CB1	Circuit breaker, 7A
CON1	Contact, Motor controller power
D	Diode D1 - Motor controller enable, 3A D2 - Motor controller, 3A
EN1	Enclosure, AC outlet box
F	Fuse F1 = 275A
FB1	Flashing beacon
GND	Ground
H	Horn or Alarm H1 = Alarm, GCON H2 = Automotive style horn (option) H3 = Alarm, PCON
JC1	Joystick controller
KS1	Key switch
LS	Limit switch LS6 = Platform down LS7 = Pothole LS8 = Pothole LS18 = Load sense (option)
M1	Hydraulic power unit
NC	Normally closed
NCHO	Normally closed held open
NOHC	Normally open held closed
OSP	Obstruction sensing pads (QSR models)
P	Red emergency stop button P1 = At ground controls P-2 At platform controls

ELECTRICAL COMPONENT LEGEND cont.	
Item	Description
QD	Quick disconnect, battery pack
	QD1 = Battery quick disconnect QD3 = Control cable to ground QD4 = Control cable to platform QD30 = AC plug QD31 = GCON ECM, ground and platform controls QD32 = GCON ECM, switches and sensors QD33 = GCON ECM, function manifold QD34 = Power buss, switches and sensors QD35 = Ground buss, switches and sensors QD36 = Pothole guard switches QD37 = Down limit switch QD38 = Level sensor QD39 = Ground buss, function manifold QD40 = Drive reverse coil, Y5 QD41 = Drive forward coil, Y6 QD42 = Steer right coil, Y3 QD43 = Steer left coil, Y4 QD44 = Platform up coil, Y8 QD45 = Obstruction pads, power signal in QD46 = Obstruction pads, power signal out QD47 = Platform controls PCB, power/signal in QD48 = Platform controls PCB, E-Stop and alarm QD49 = Platform controls PCB, joystick
R	Resistor R1 = 1k Ohm, 2W R2 = 200 Ohm, 10W R27 = 25 Ohm, 2W R30 = 200 Ohm, 10W
S7	Level sensor
U	Electronic Component
	U1 = Electronic Control Module, GCON U2 = Printed Circuit Board, PCON U4 = AC/DC Inverter (option) U6 = Motor Controller U9 = Battery Charger U47A = Obstruction sensing pad (hydraulic tank side) U47B = Obstruction sensing pad (battery tray) U47C = Obstruction sensing pad (steer end) U47D = Obstruction sensing pad (ground control side)
Y	Valve Coil  Y3 = Steer right Y4 = Steer left Y5 = Drive reverse Y6 = Drive forward Y7 = Platform Down Y8 = Platform Up
Z1	Zener diode

## Electrical Component and Wire Color Legends







WIRE COLOR LEGEND	
Color	Description
BK	Black
BK/RD	Black/Red
BL	Blue
BL/BK	Blue/Black
BL/OR	Blue/Orange
BL/WH	Blue/White
BR	Brown
GR	Green
GR/BK	Green/Black
GR/WH	Green/White
GR/YL	Green/Yellow
LB	Light Blue
OR	Orange
OR/BK	Orange/Black
OR/RD	Orange/Red
OR/WH	Orange/White
RD	Red
RD/BK	Red/Black
RD/WH	Red/White
WH	White
WH/BK	White/Black
YL	Yellow

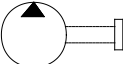
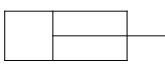
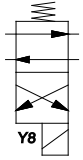

# Electrical Symbol Legend

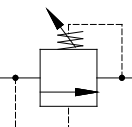
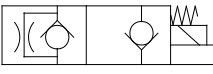
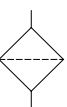
<p>Wire with description or color</p>	<p>Limit Switch</p>	<p>Motor controller</p>	<p>Key switch</p>
<p>Circuits crossing no connection</p>	<p>Emergency Stop button</p>	<p>Motor</p>	<p>Solenoid valve with diode</p>
<p>Diode</p>	<p>Circuit breaker</p>	<p>Battery charger</p>	<p>Level sensor</p>
<p>Circuit connection</p>	<p>Fuse</p>	<p>6V or 12V DC battery</p>	<p>Deutsch connector</p>
<p>Resistor</p>	<p>Contactor</p>	<p>Horn or alarm</p>	<p>Flashing beacon</p>

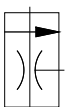
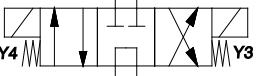
# Hydraulic Symbols Legend

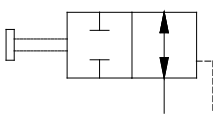
 <p>0.037 in 0.94 mm</p>			
<p>Orifice with size</p>	<p>Hydraulic hand pump</p>	<p>Hydraulic cylinder</p>	<p>Solenoid operated 2 position 4 way directional valve</p>
			
<p>Check valve</p>	<p>Fixed displacement pump</p>	<p>Relief valve</p>	<p>Solenoid operated 2 position 2 way directional valve, normally closed with manual override</p>
			
<p>Filter</p>	<p>Bi-directional motor</p>	<p>Priority flow regulator</p>	<p>Solenoid operated 3 position 4 way directional valve</p>
			
<p>Brake</p>	<p>Variable speed motor</p>	<p>Pilot operated needle valve</p>	

**Electrical Schematic, GR • QSW, ANSI / CSA**  
(from serial numbers GR10-20000 to GR11-20683 and QS11-1000 to QS11-1015)

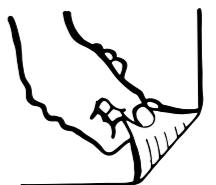



### Electrical Schematic, GR • QSW, ANSI / CSA

(from serial numbers GR10-20000 to GR11-20683 and QS11-1000 to QS11-1015)

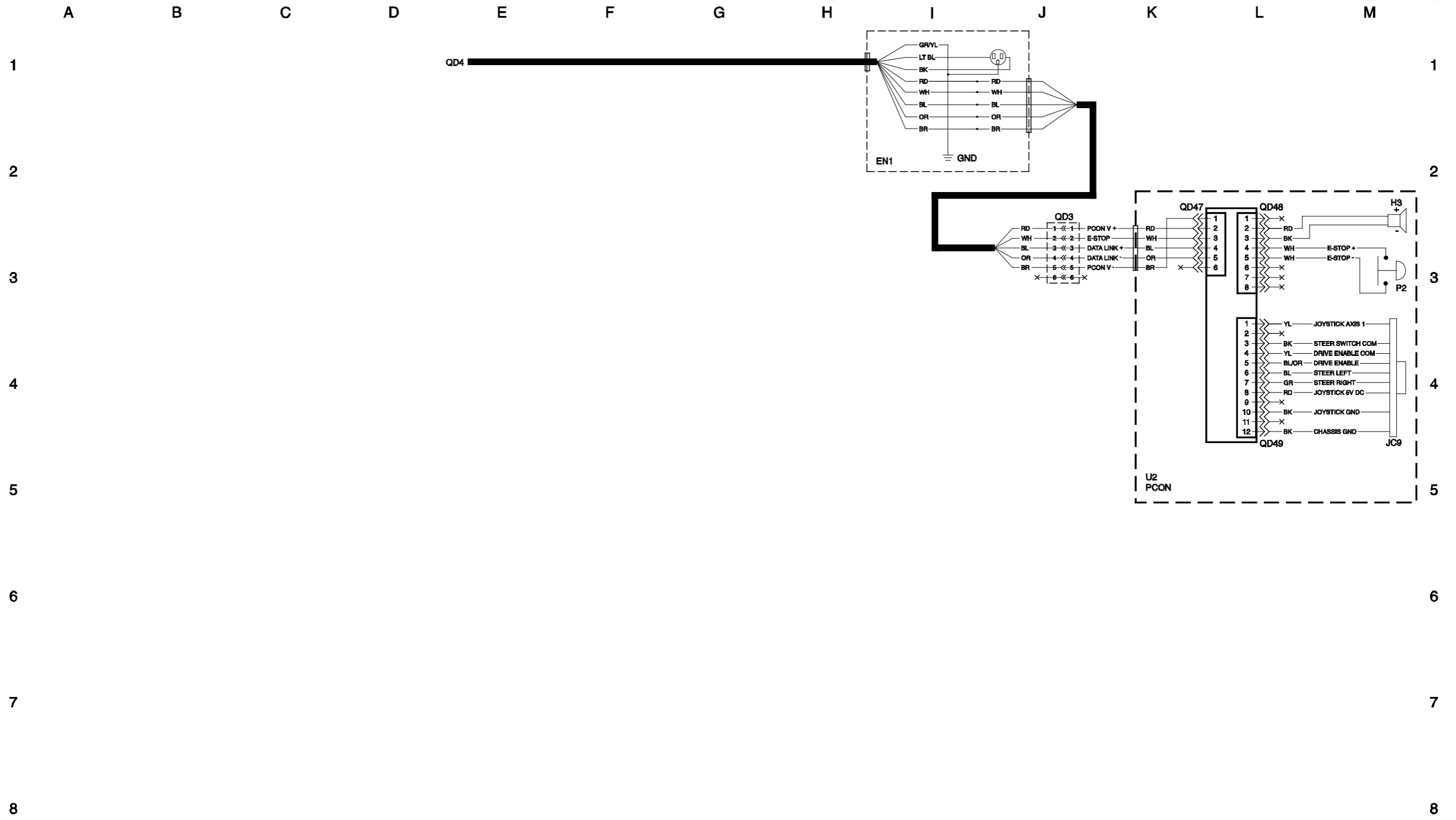

**Electrical Schematic, GR • QSW, ANSI / CSA**

(from serial numbers GR10-20000 to GR11-20683 and QS11-1000 to QS11-1015)

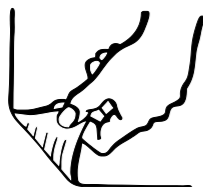

**Electrical Schematic, GR • QSW, ANSI / CSA**  
(from serial numbers GR11-20684 to GR14-29741 and QS11-1016 to QS14-1550)

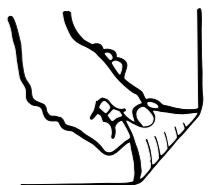

# Electrical Schematic, GR • QSW, ANSI / CSA

(from serial numbers GR11-20684 to GR14-29741 and QS11-1016 to QS14-1550)

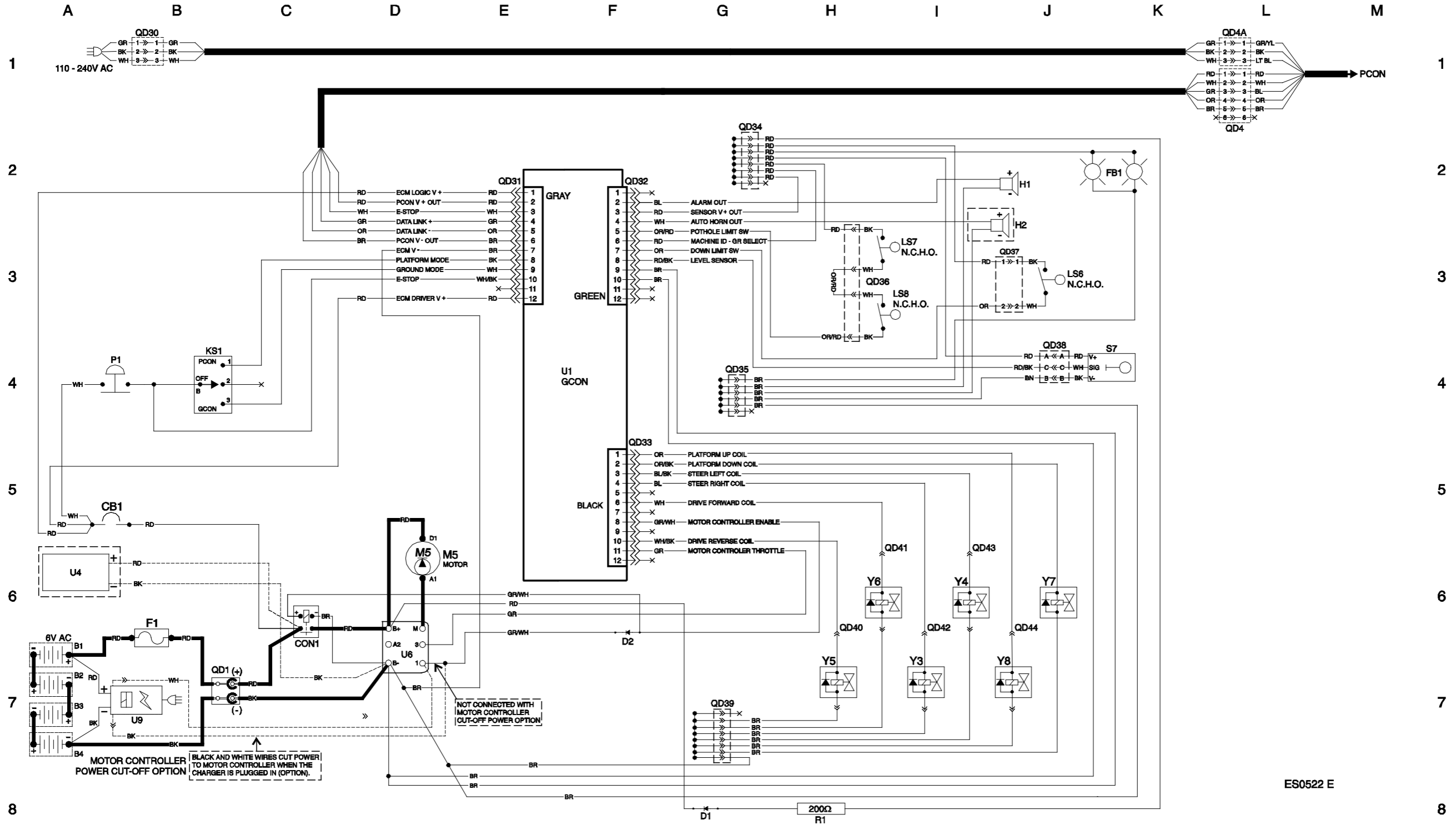

ES0522 E

**Electrical Schematic, GR • QSW, ANSI / CSA**

(from serial numbers GR11-20684 to GR14-29741 and QS11-1016 to QS14-1550)

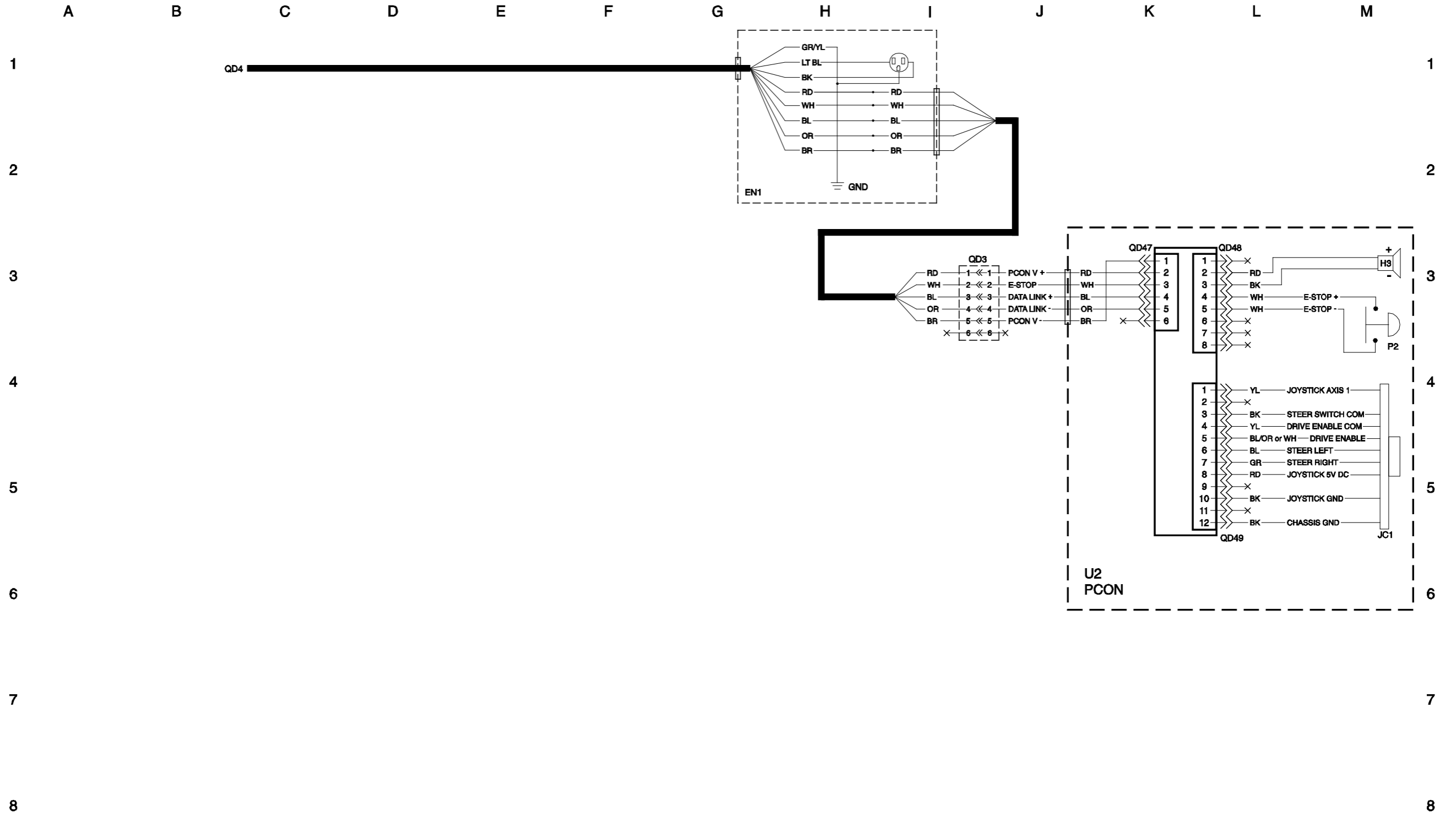

**Electrical Schematic, GR • QSW, ANSI / CSA**

(from serial numbers GR11-20684 to GR14-29741 and QS11-1016 to QS14-1550)

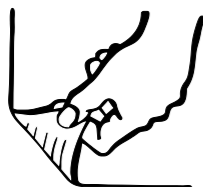

**Electrical Schematic, GR • QSW, ANSI / CSA**  
(from serial numbers GR14-29742 to GR15-40225 and QS14-1551 to QS15-2426)

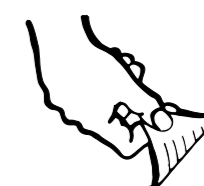

# Electrical Schematic, GR • QSW, ANSI / CSA

(from serial numbers GR14-29742 to GR15-40225 and QS14-1551 to QS15-2426)

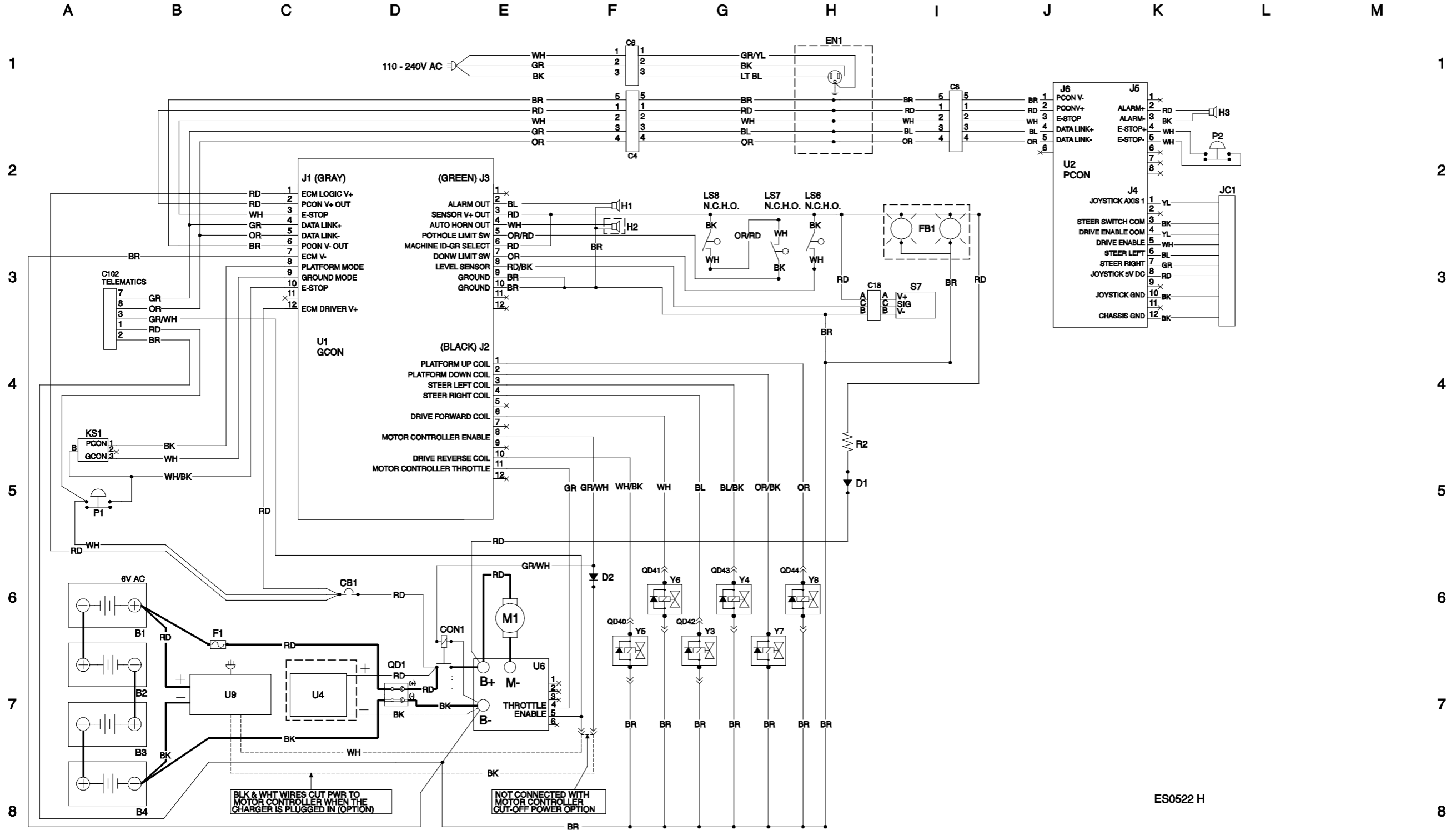

### Electrical Schematic, GR • QSW, ANSI / CSA (from serial numbers GR15-40226 to GR16P-41919 and QS15-2427 to QS16P-2451)

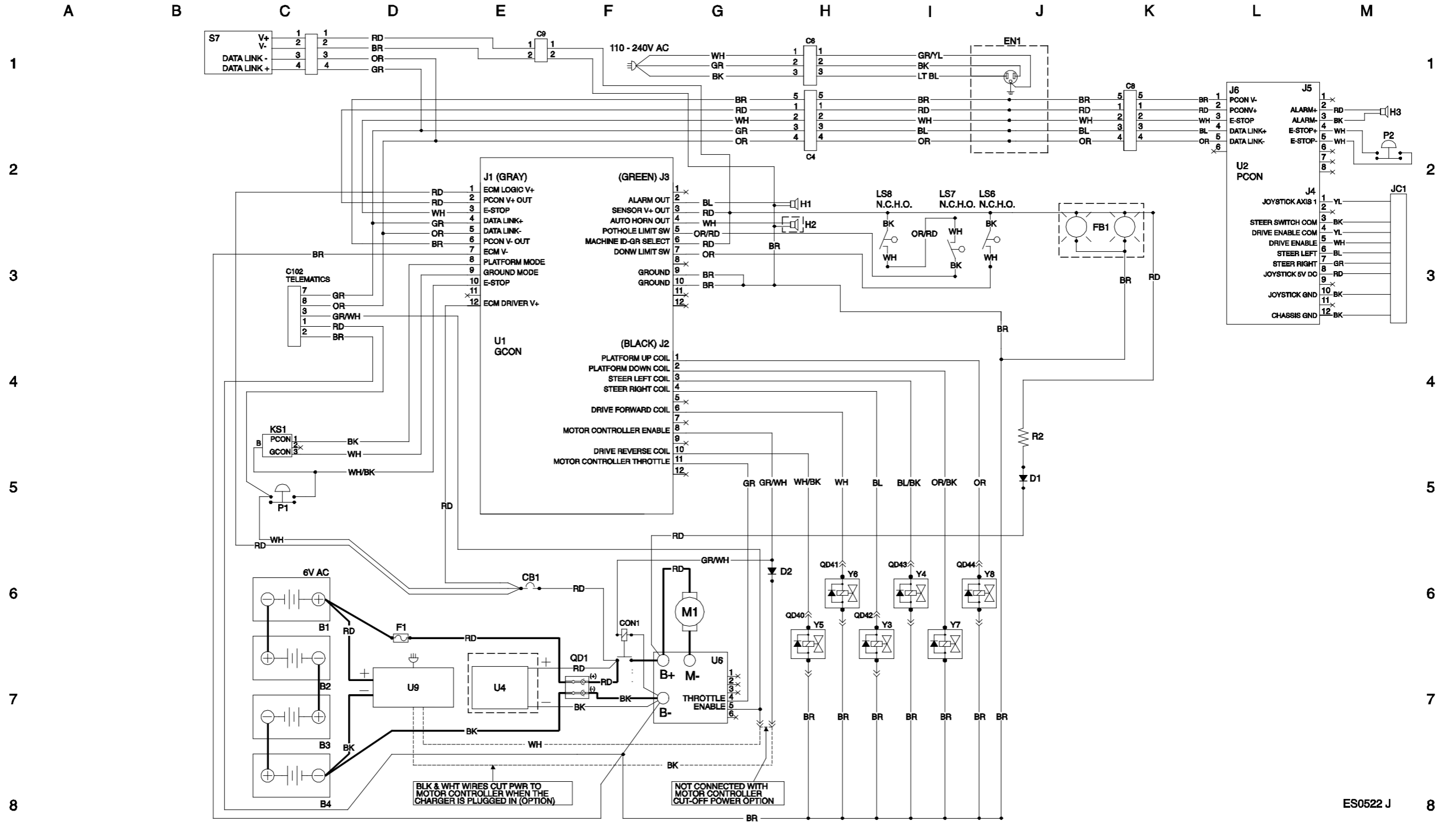

**Electrical Schematic, GR • QSW, ANSI / CSA**

(from serial numbers GR15-40226 to GR16P-41929 and QS15-2427 to QS16P-2451)

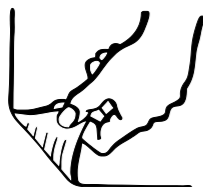

**Electrical Schematic, GR • QSW, ANSI / CSA**  
(from serial numbers GR16P-41930 to GR16P-44173 and QS16P-2452 to QS16P-2469)

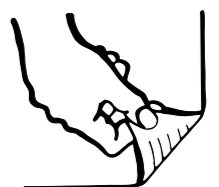

# Electrical Schematic, GR • QSW, ANSI / CSA

(from serial numbers GR16P-41930 to GR16P-44173 and QS16P-2452 to QS16P-2468)

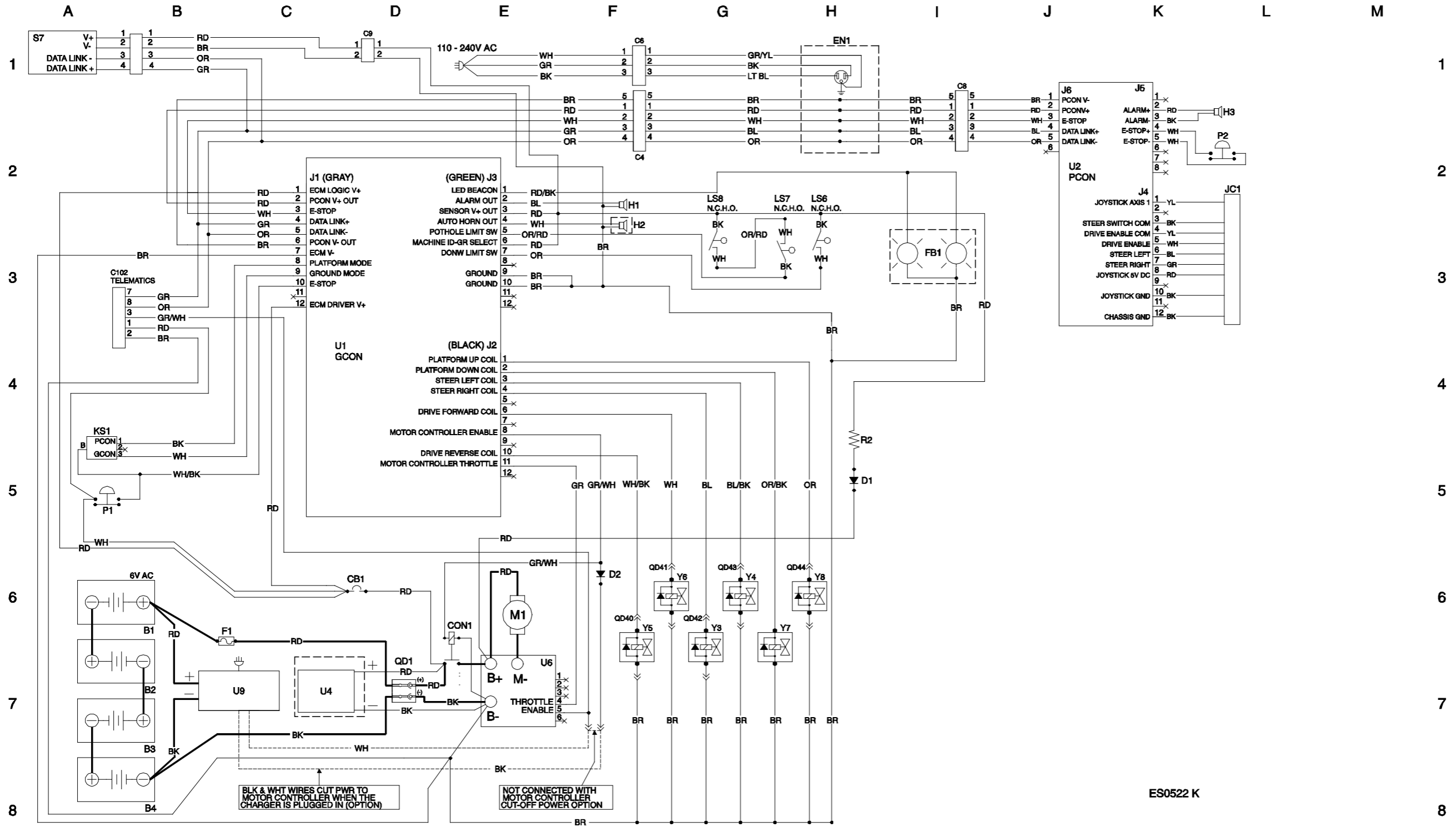

ES0522 K

### Electrical Schematic, GR • QSW, ANSI / CSA

(from serial numbers GR16P-44174 to GR16P-46499 and QS16P-2469 to QS16P-4499)  
(from serial numbers GRP-46500 and QSP-4500)

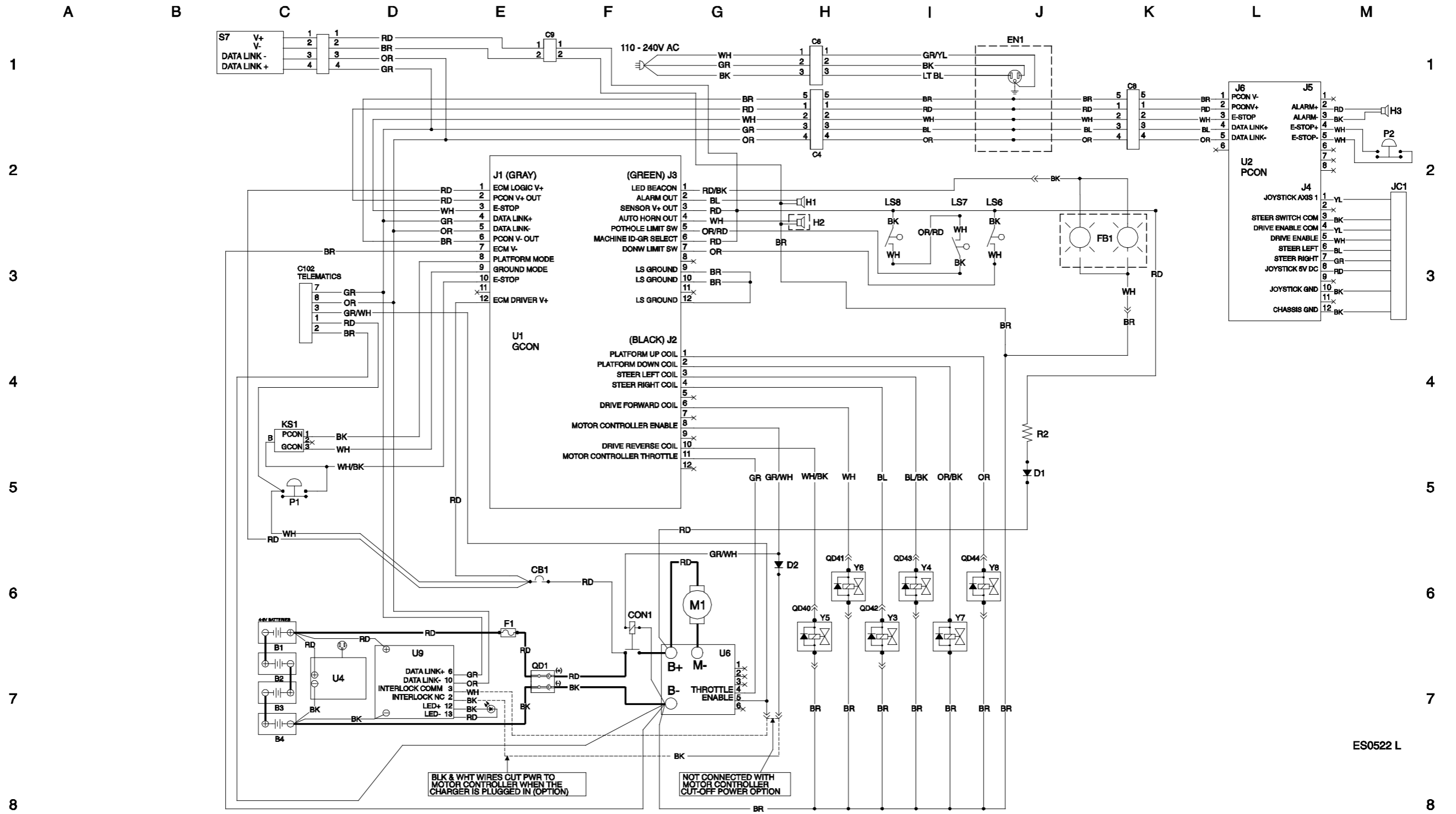

ES0522 L



**Electrical Schematic, GR • QSW, ANSI / CSA**

(from serial numbers GR16P-44174 to GR16P-46499 and QS16P-2469 to QS16P-4499)

(from serial numbers GRP-46500 and QSP-4500)

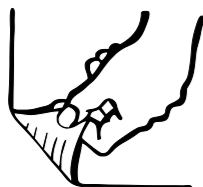

**Electrical Schematic, QSR, ANSI / CSA**  
(from serial number QS11-1000 to QS11-1015)

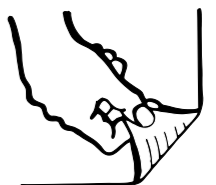

# Electrical Schematic, QSR, ANSI / CSA (from serial number QS11-1000 to QS11-1015)

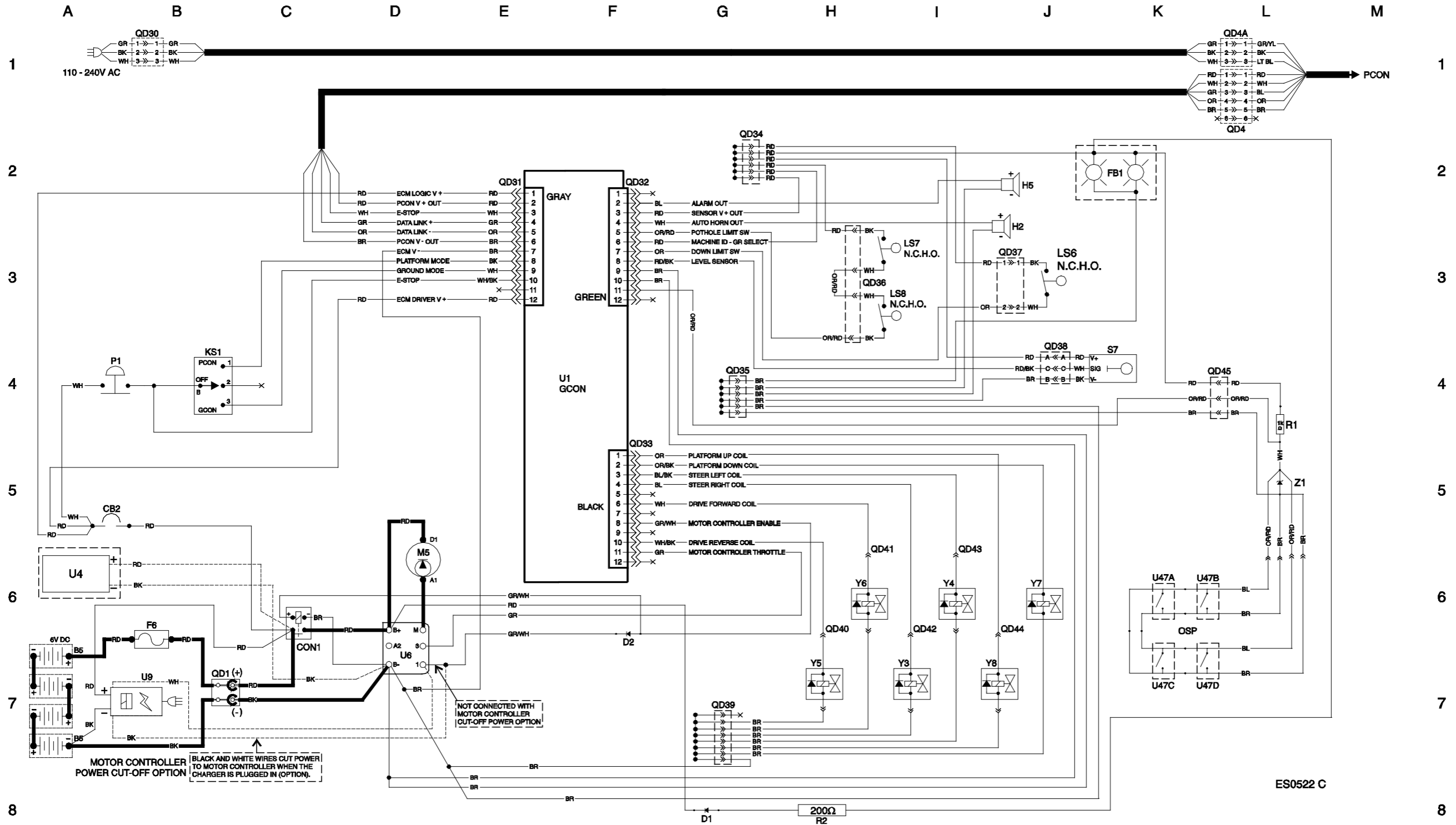

**Electrical Schematic, QSR, ANSI / CSA**  
(from serial number QS11-1000 to QS11-1015)



**Electrical Schematic, QSR, ANSI / CSA**  
(from serial number QS11-1000 to QS11-1015)

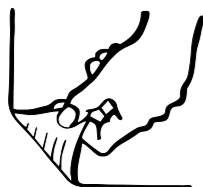

**Electrical Schematic, QSR, ANSI / CSA**  
(from serial number QS11-1016 to QS14-1550)

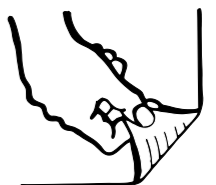

# Electrical Schematic, QSR, ANSI / CSA

(from serial number QS11-1016 to QS14-1550)

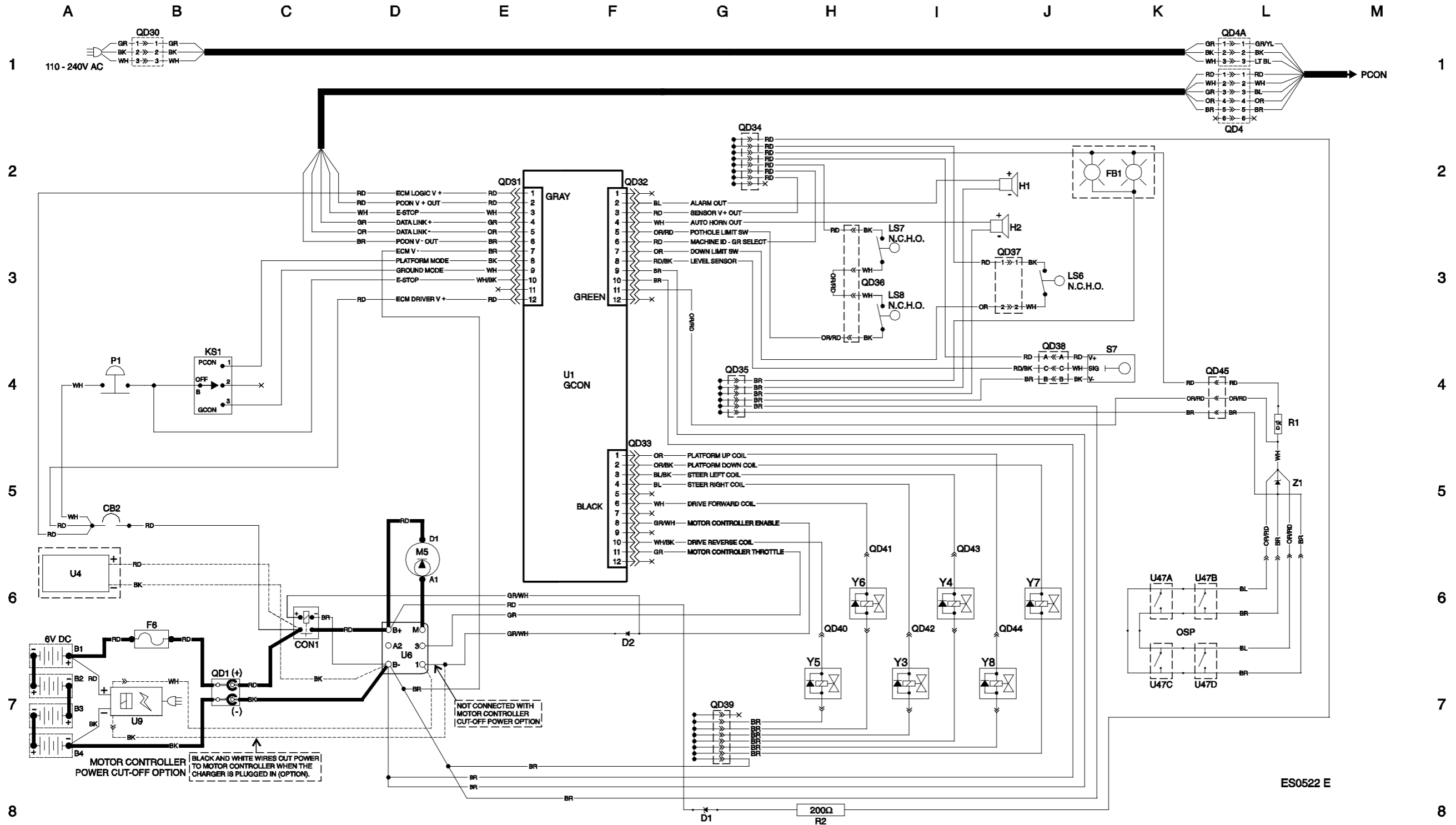

**Electrical Schematic, QSR, ANSI / CSA**  
(from serial number QS11-1016 to QS14-1550)

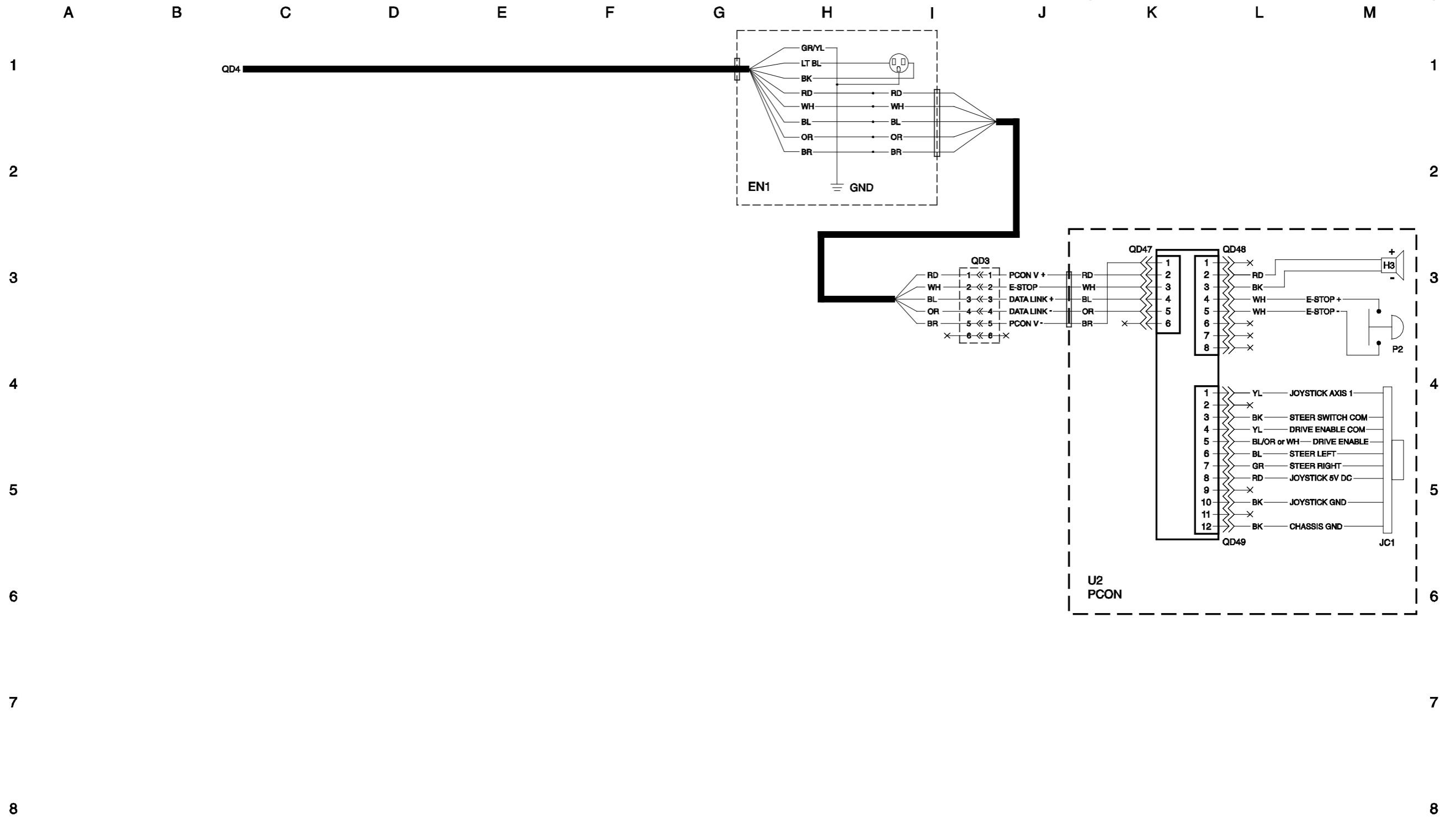

**Electrical Schematic, QSR, ANSI / CSA**  
(from serial number QS11-1016 to QS14-1550)

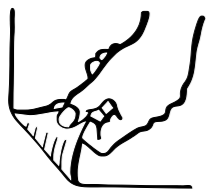

**Electrical Schematic, QSR, ANSI / CSA**  
(from serial number QS14-1551 to QS15-2426)

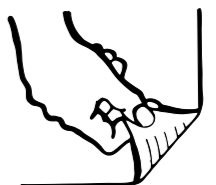

# Electrical Schematic, QSR, ANSI / CSA (from serial number QS14-1551 to QS15-2426)

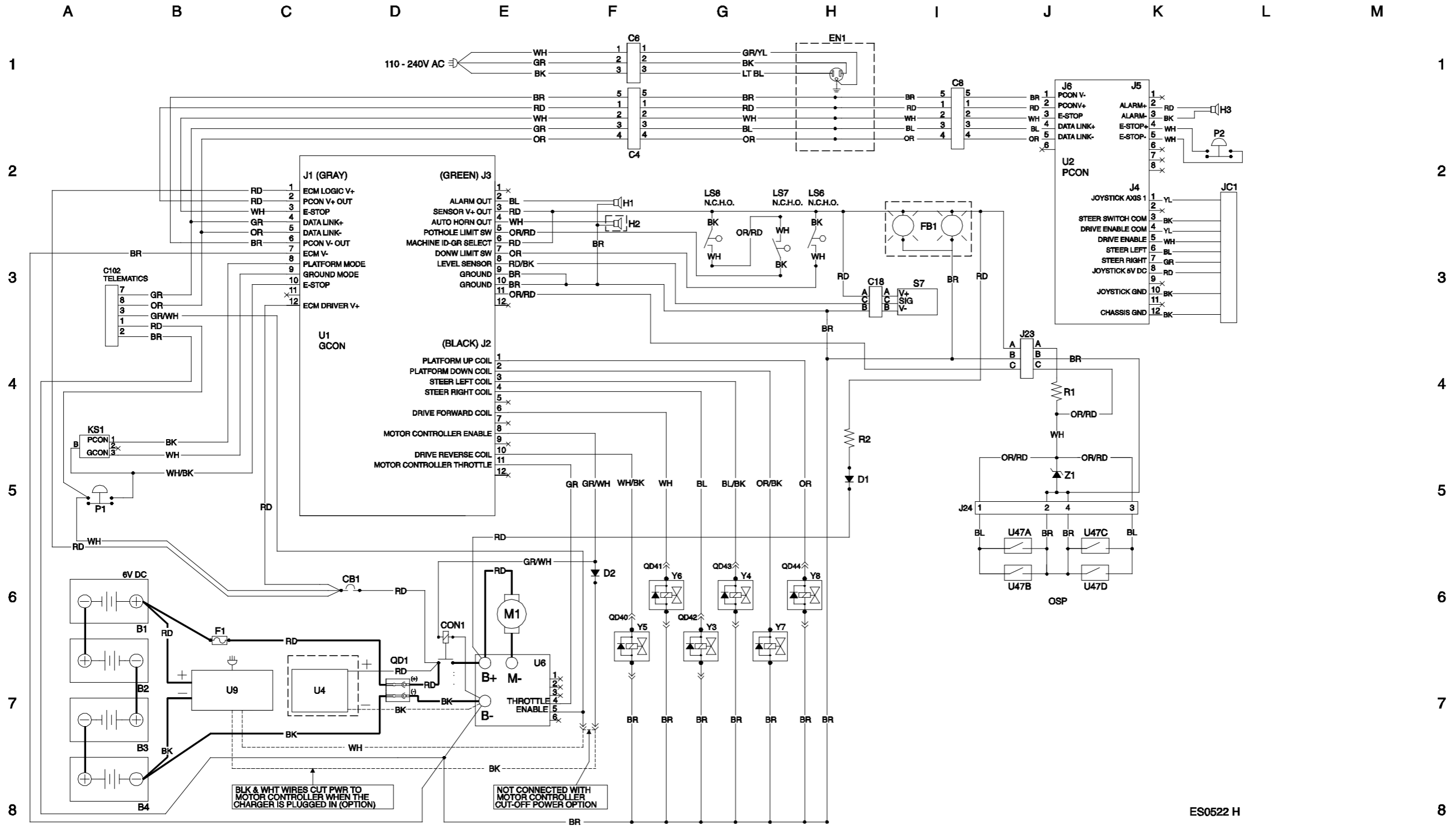

### Electrical Schematic, QSR, ANSI / CSA (from serial number QS15-2427 to QS16P-2451)

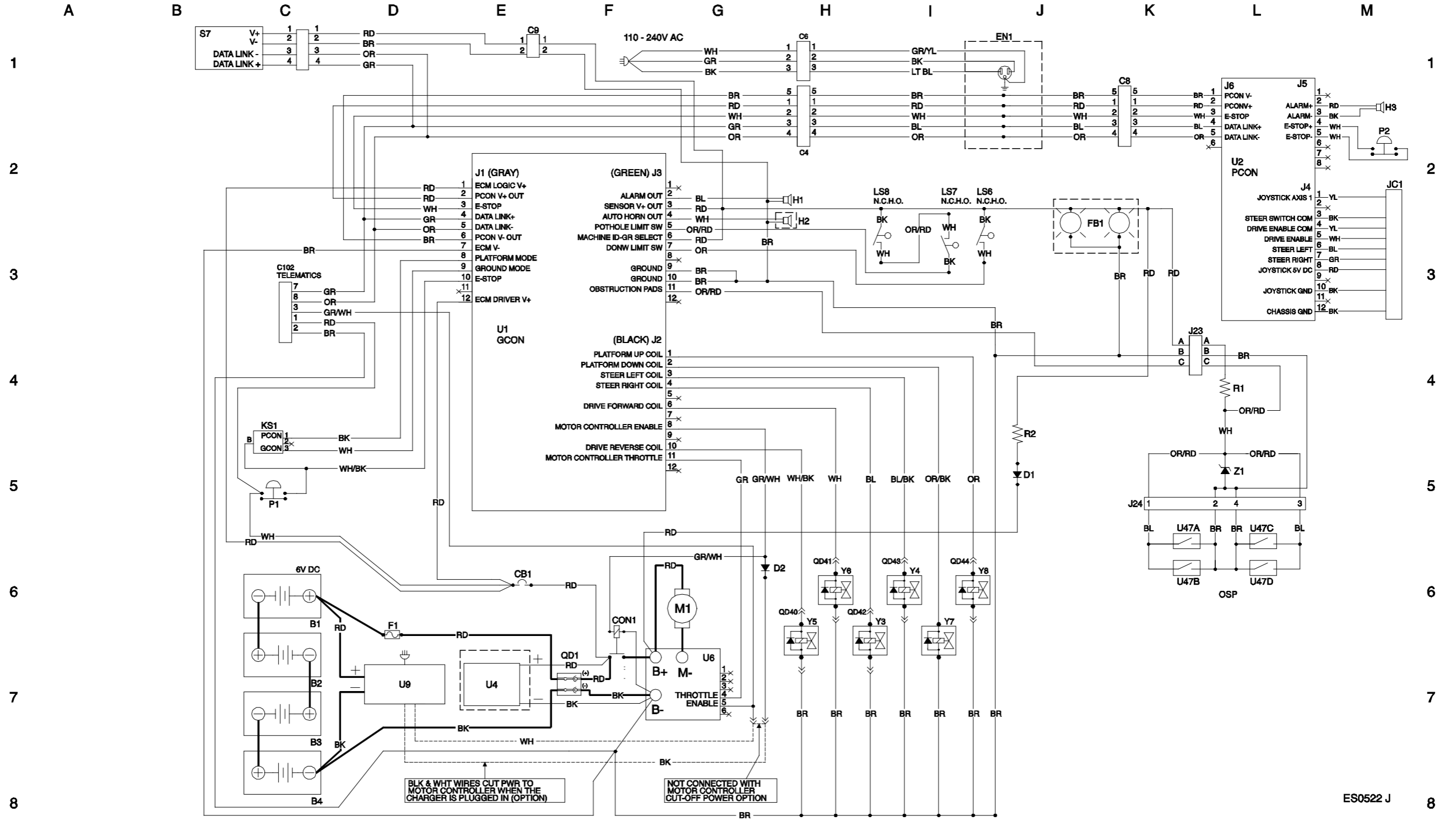

ES0522 J 8

**Electrical Schematic, QSR, ANSI / CSA**  
(from serial number QS15-2427 to QS16P-2451)

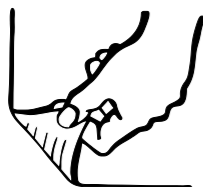

**Electrical Schematic, QSR, ANSI / CSA**  
**(from serial number QS16P-2452 to QS16P-2468)**

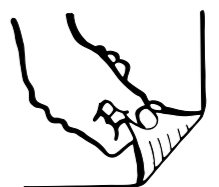

### Electrical Schematic, QSR, ANSI / CSA (from serial number QS16P-2452 to QS16P-2468)

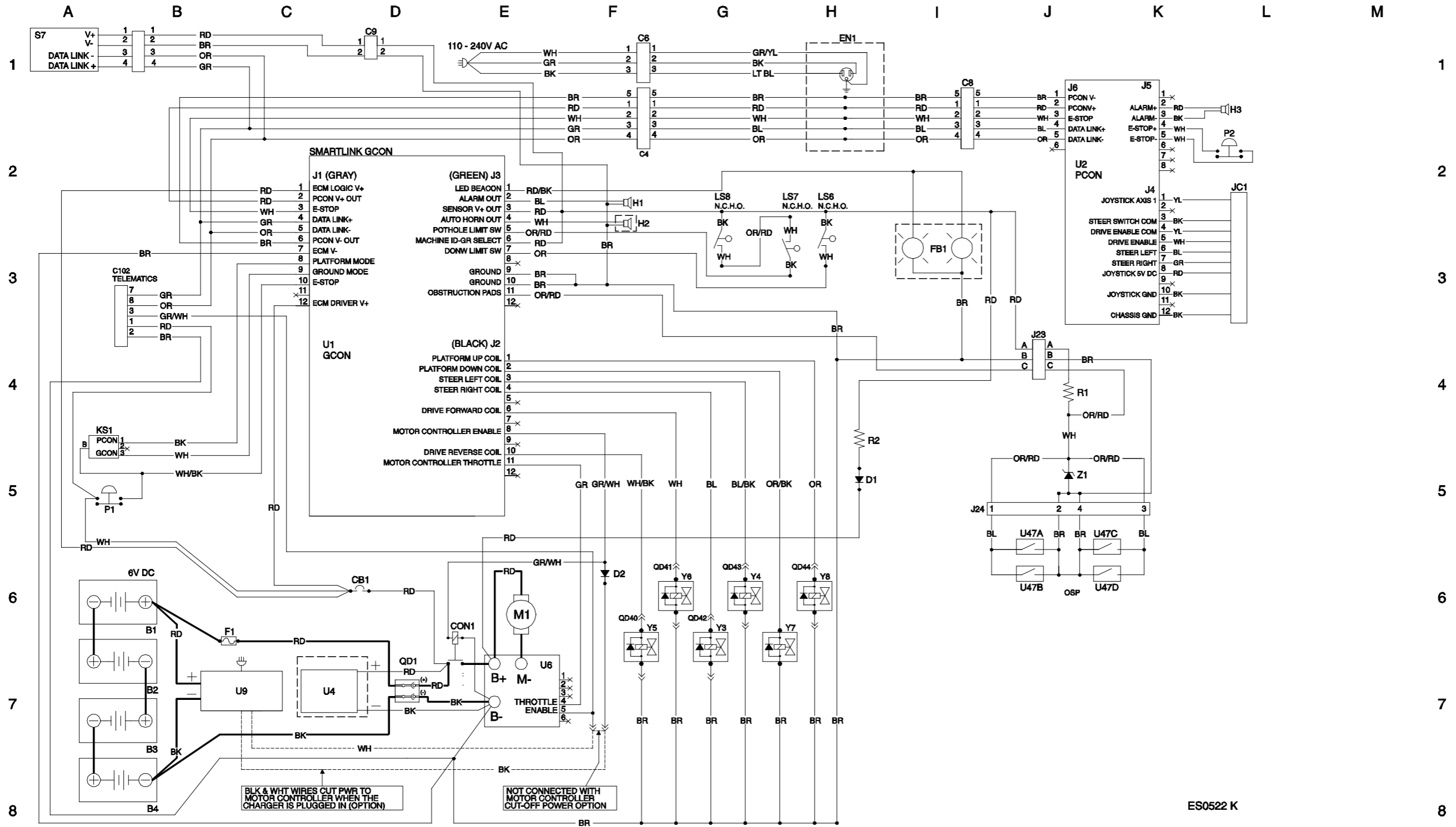

# Electrical Schematic, QSR, ANSI / CSA (from serial number QS16P-2469 to QS16P-4499) (from serial number QSP-4500)

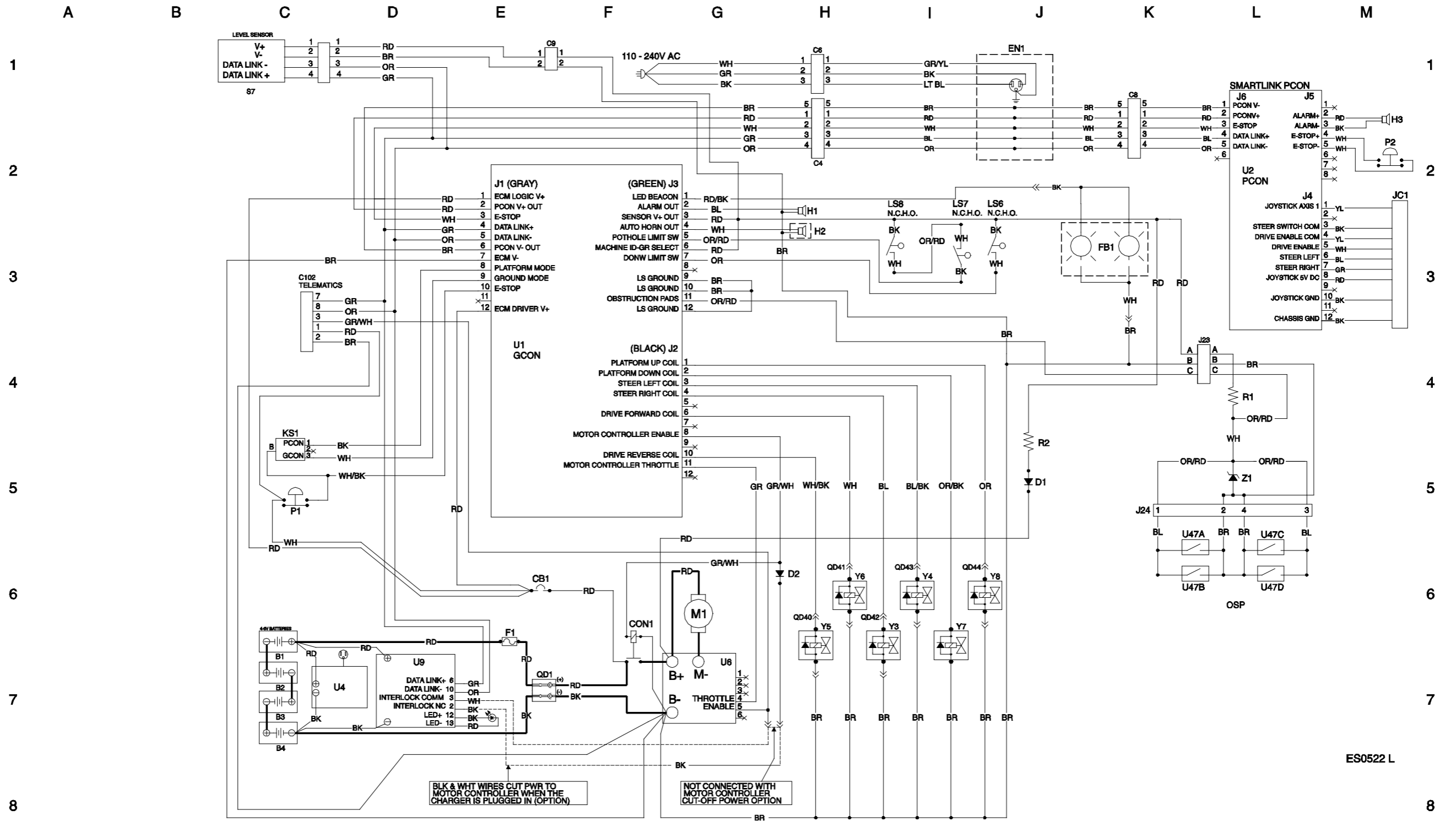

**Electrical Schematic, QSR, ANSI / CSA**

(from serial number QS16P-2469 to QS16P-4499)

(from serial number QSP-4500)

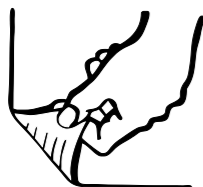

**Electrical Schematic, GR • QSW, AS / CE**  
(from serial numbers GR10-20000 to GR11-20683 and QS11-1000 to QS11-1015)

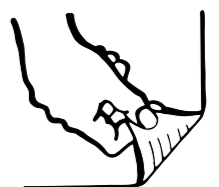

# Electrical Schematic, GR • QSW, AS / CE

(from serial numbers GR10-20000 to GR11-20683 and QS11-1000 to QS11-1015)

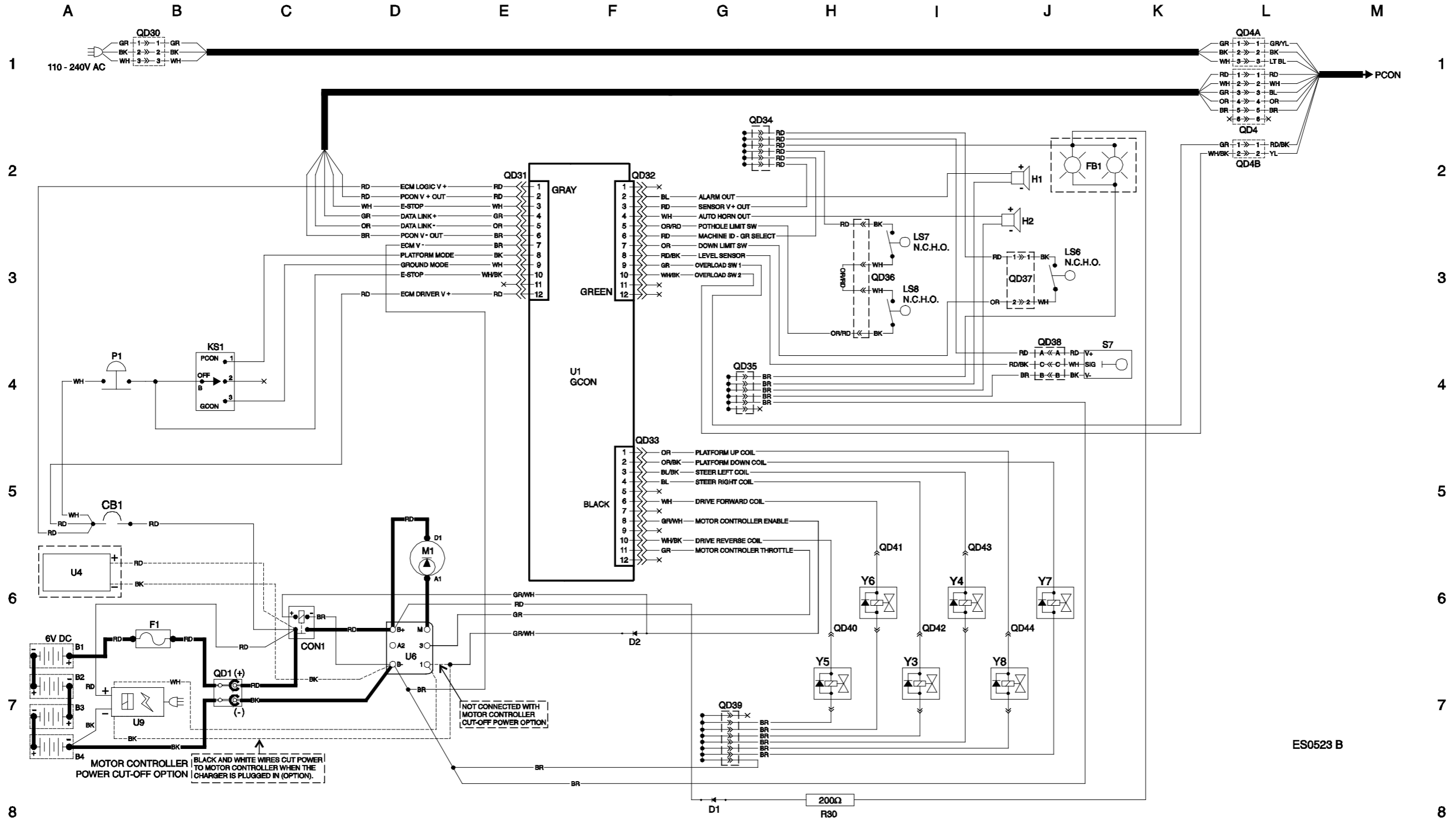

### Electrical Schematic, GR • QSW, AS / CE

(from serial numbers GR10-20000 to QR11-20683 and QS11-1000 to QS11-1015)

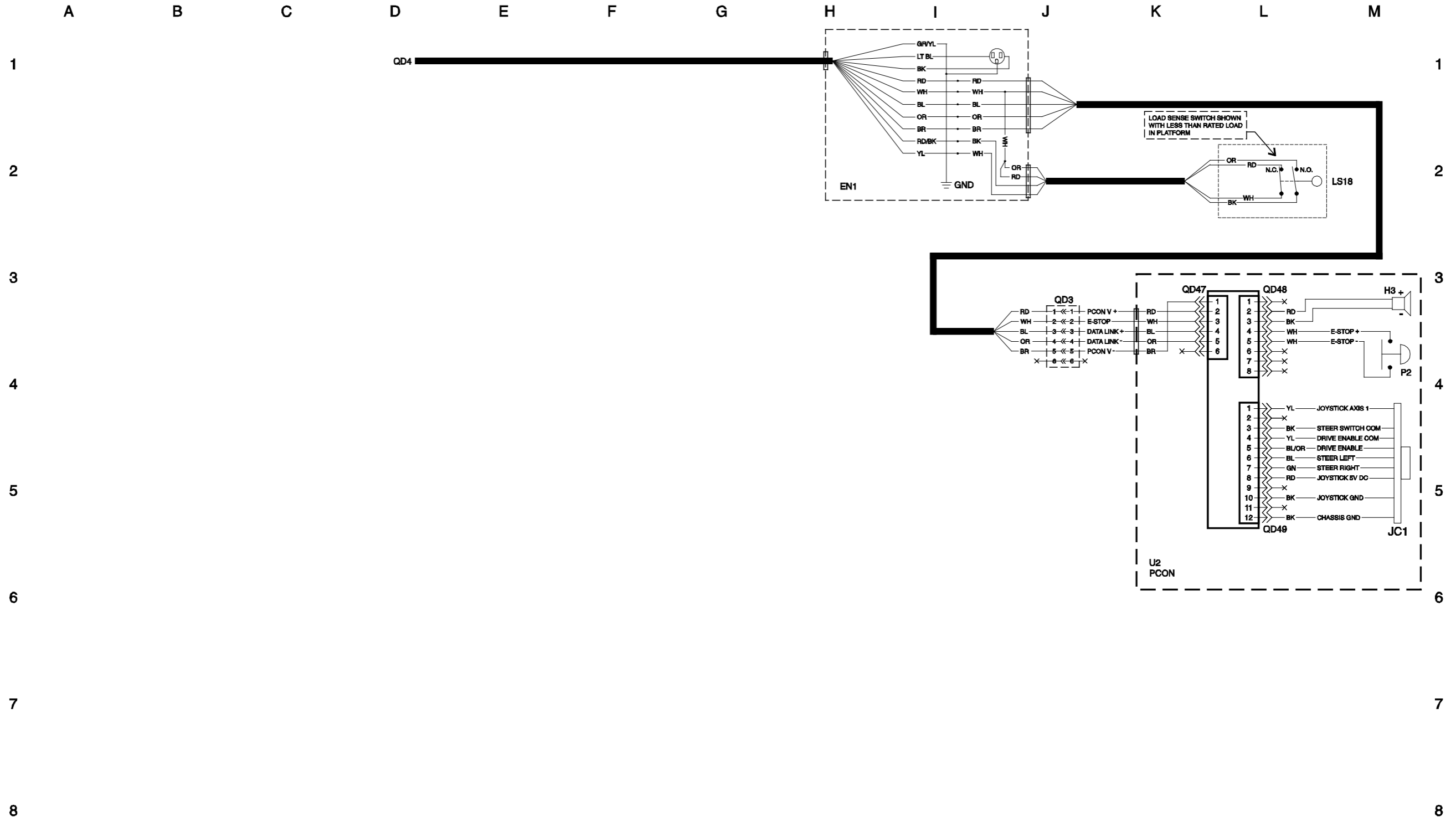

**Electrical Schematic, GR • QSW, AS / CE**

(from serial numbers GR10-20000 to GR11-20683 and QS11-1000 to QS11-1015)

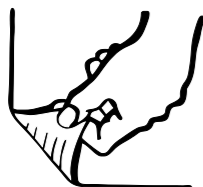

**Electrical Schematic, GR • QSW, AS / CE**  
(from serial numbers GR11-20684 to GR14-29741 and QS11-1016 to QS14-1550)

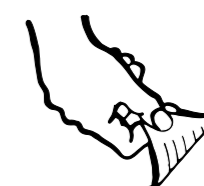

# Electrical Schematic, GR • QSW, AS / CE

(from serial numbers GR11-20684 to GR14-29741 and QS11-1016 to QS14-1550)

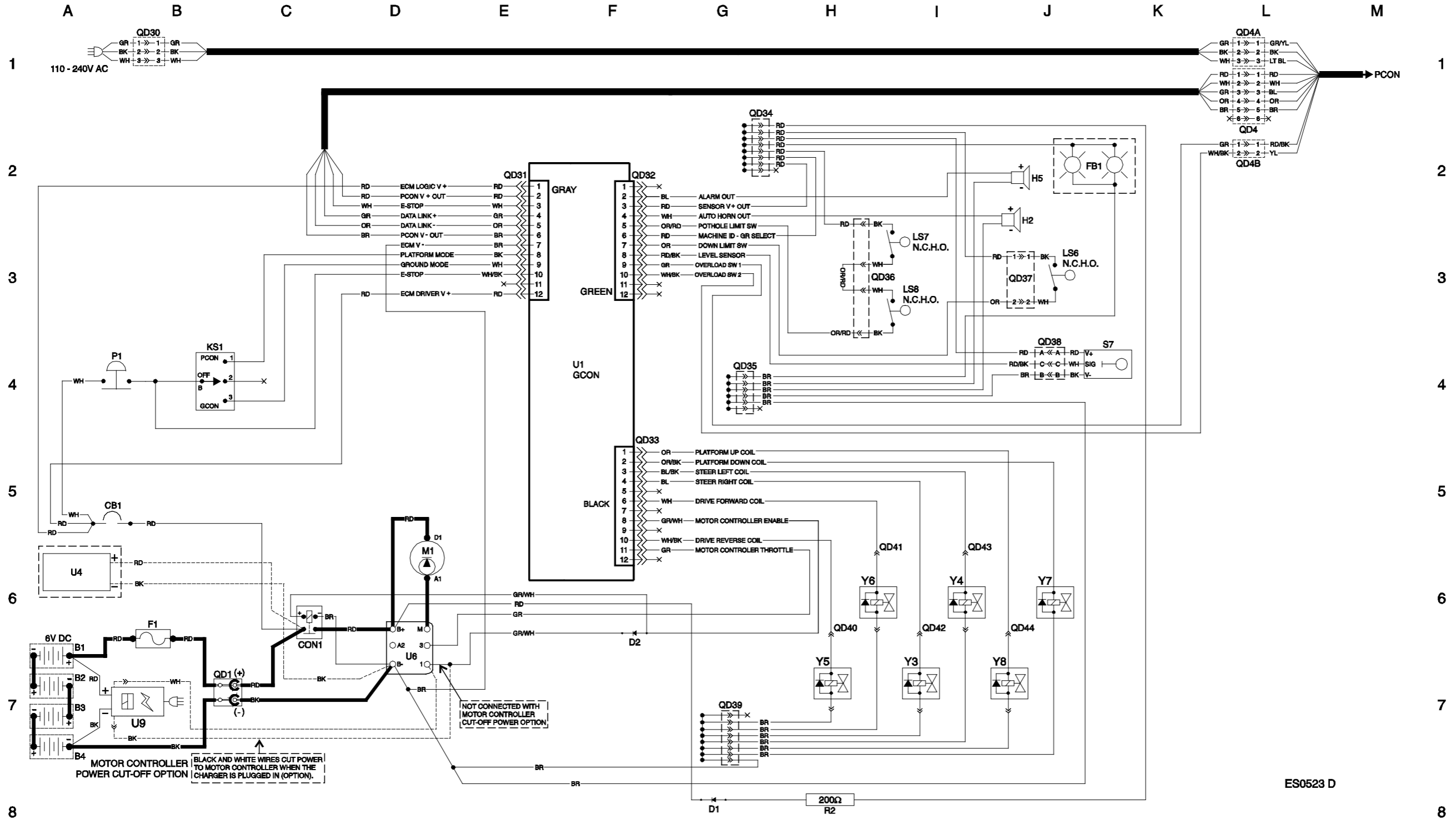

ES0523 D



**Electrical Schematic, GR • QSW, AS / CE**

(from serial numbers GR11-20684 to GR14-29741 and QS11-1016 to QS14-1550)

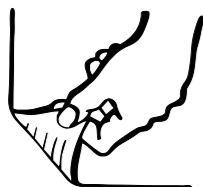

**Electrical Schematic, GR • QSW, AS / CE**  
(from serial numbers GR14-29742 to GR15-40225 and QS14-1551 to QS15-2426)

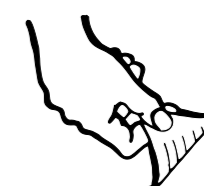

# Electrical Schematic, GR • QSW, AS / CE

(from serial numbers GR14-29742 to GR15-40225 and QS14-1551 to QS15-2426)

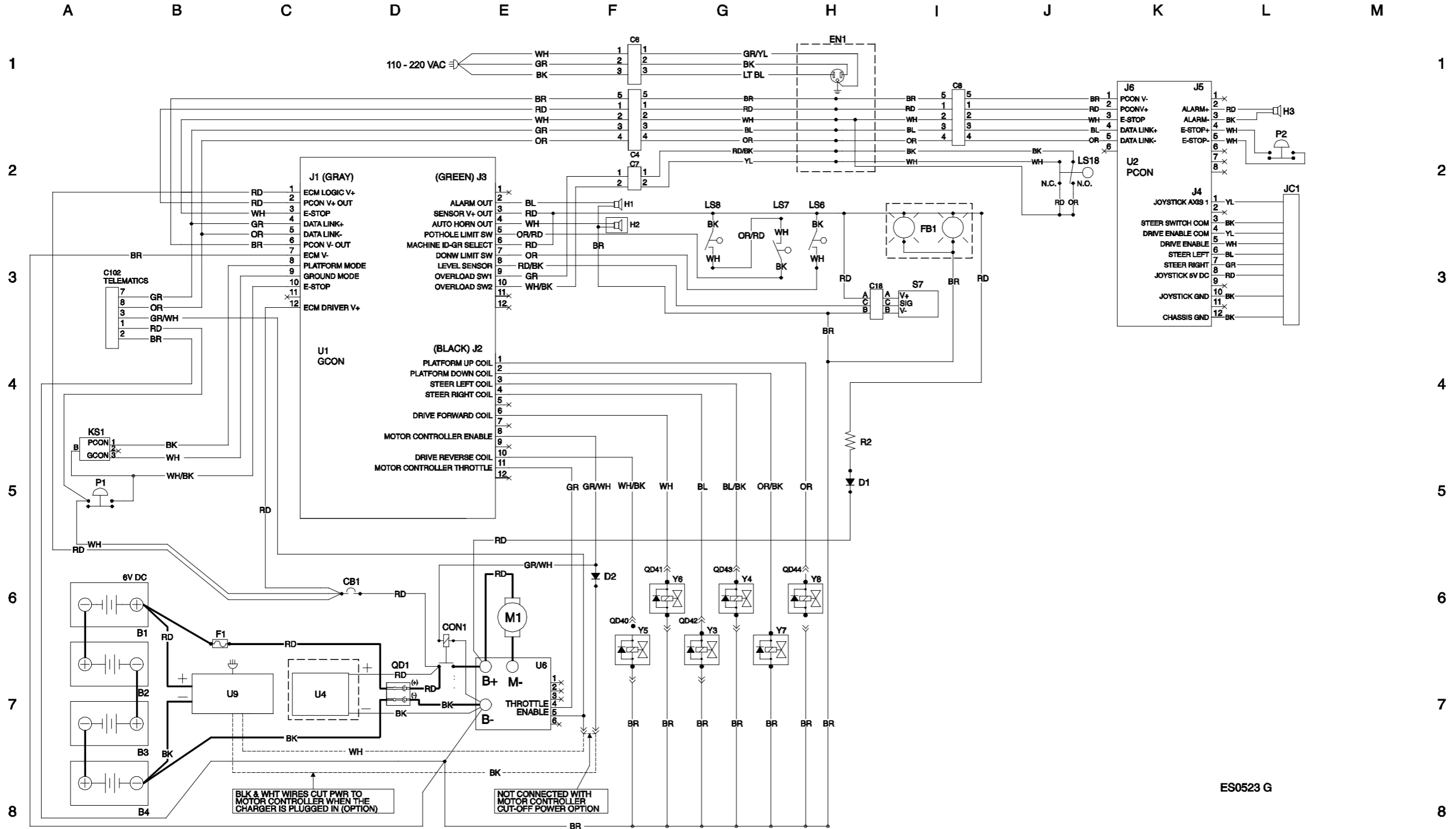

BLK & WHT WIRES CUT PWR TO MOTOR CONTROLLER WHEN THE CHARGER IS PLUGGED IN (OPTION)

NOT CONNECTED WITH MOTOR CONTROLLER CUT-OFF POWER OPTION

ES0523 G





**Electrical Schematic, GR • QSW, AS / CE**

(from serial numbers GR15-40226 to GR16P-41929 and QS15-2427 to QS16P-2451)

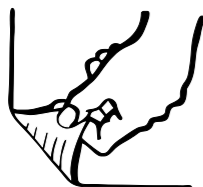

---

**Electrical Schematic, GR • QSW, AS / CE**  
(from serial numbers GR16P-41930 to GR16P-44173 and QS16P-2452 to QS16P-2468)

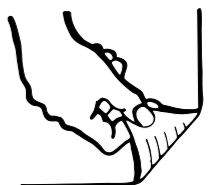

# Electrical Schematic, GR • QSW, AS / CE

(from serial numbers GR16P-41930 to GR16P-44173 and QS16P-2452 to QS16P-2468)

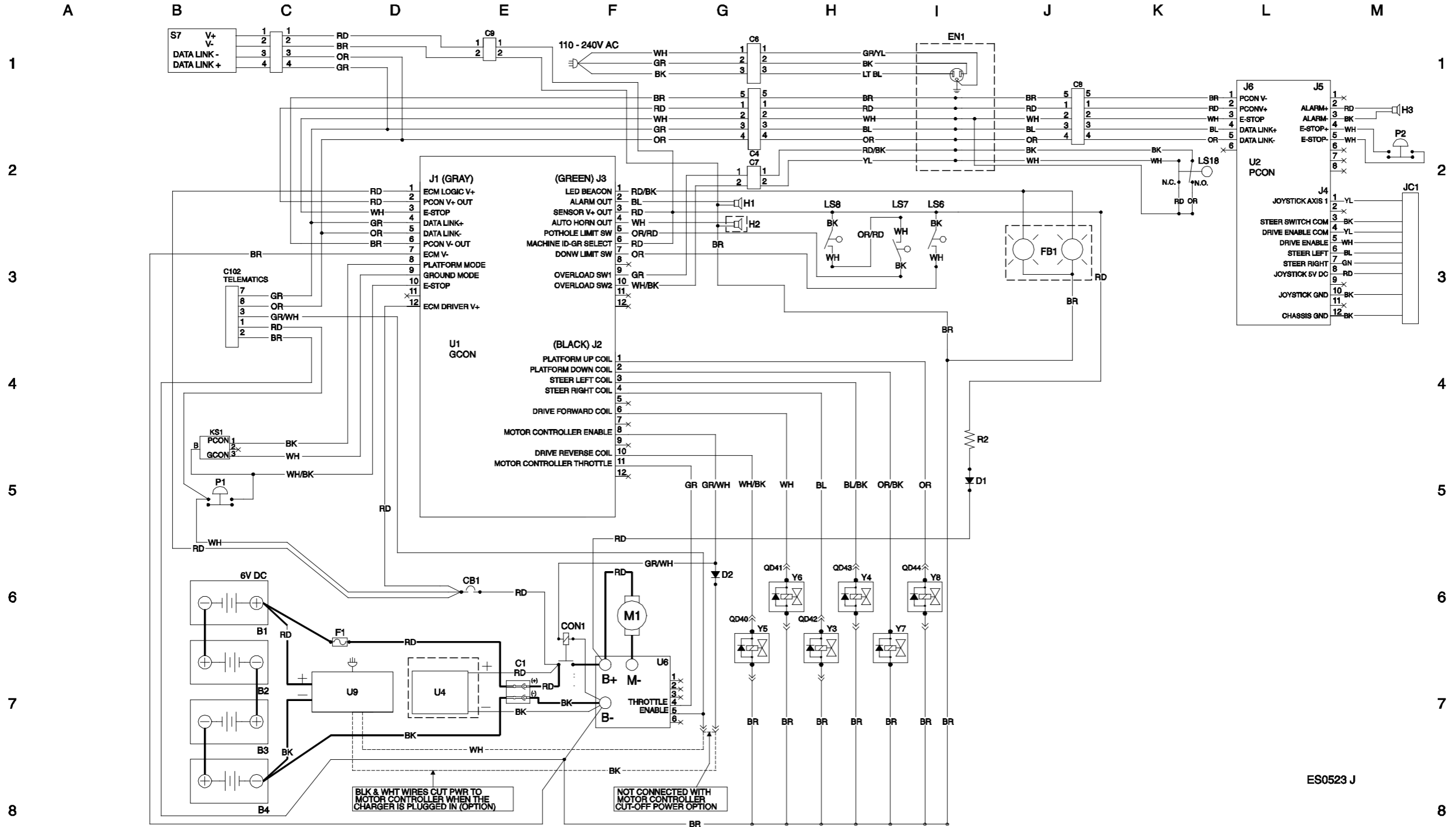

### Electrical Schematic, GR • QSW, AS / CE

(from serial numbers GR16P-44174 to GR16P-46499 and QS16P-2469 to QS16P-4499)  
(from serial numbers GRP-46500 and QSP-4500)

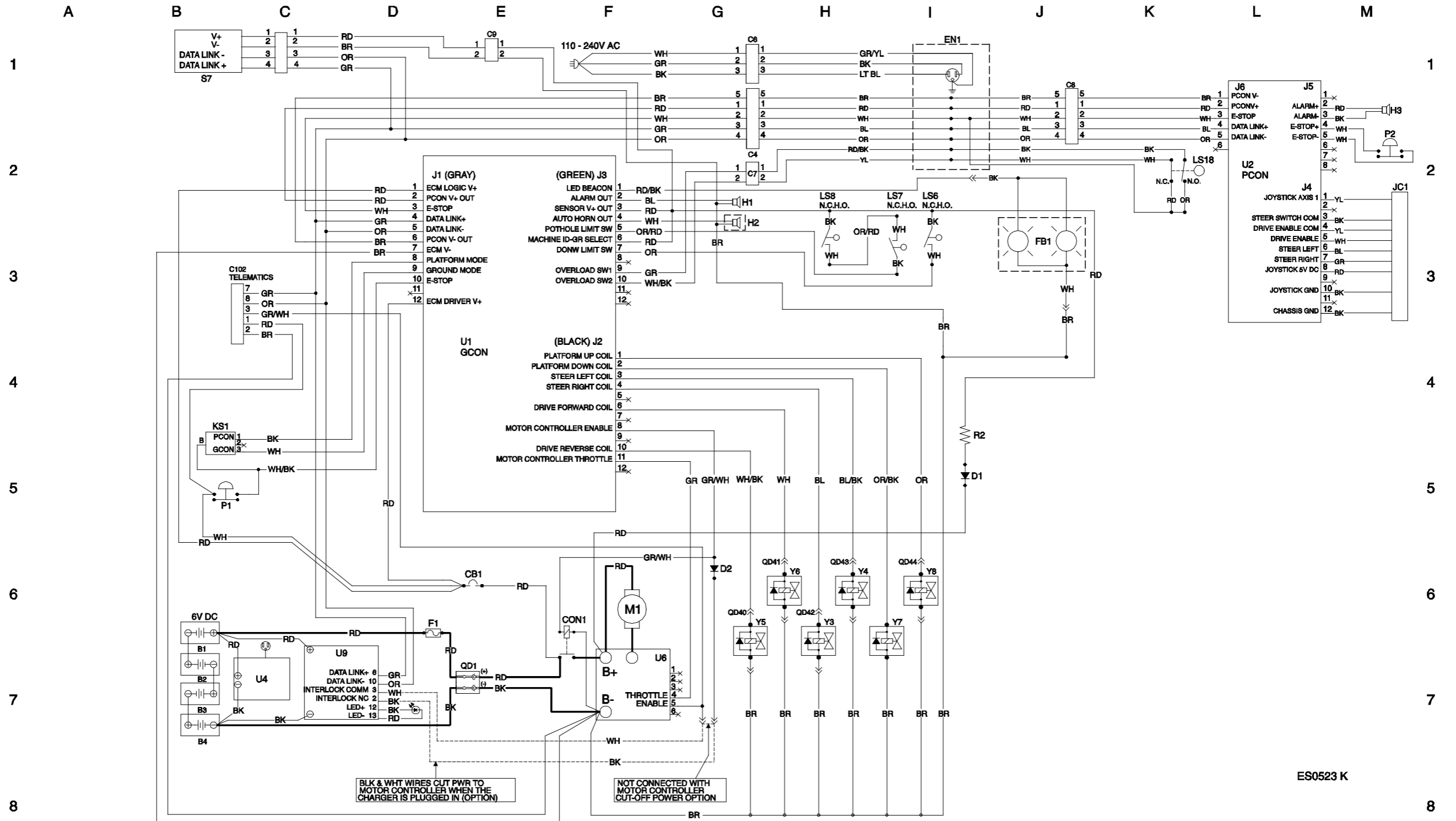

**Electrical Schematic, GR • QSW, AS / CE**

(from serial numbers GR16P-44174 to GR16P-46499 and QS16P-2469 to QS16P-4499)

(from serial numbers GRP-46500 and QSP-4500)

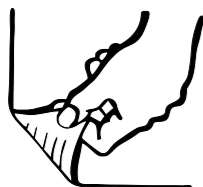

**Electrical Schematic, QSR, AS / CE**  
(from serial number QS11-1000 to QS11-1015)

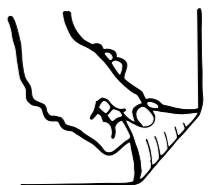

# Electrical Schematic, QSR, AS / CE

(from serial number QS11-1000 to QS11-1015)

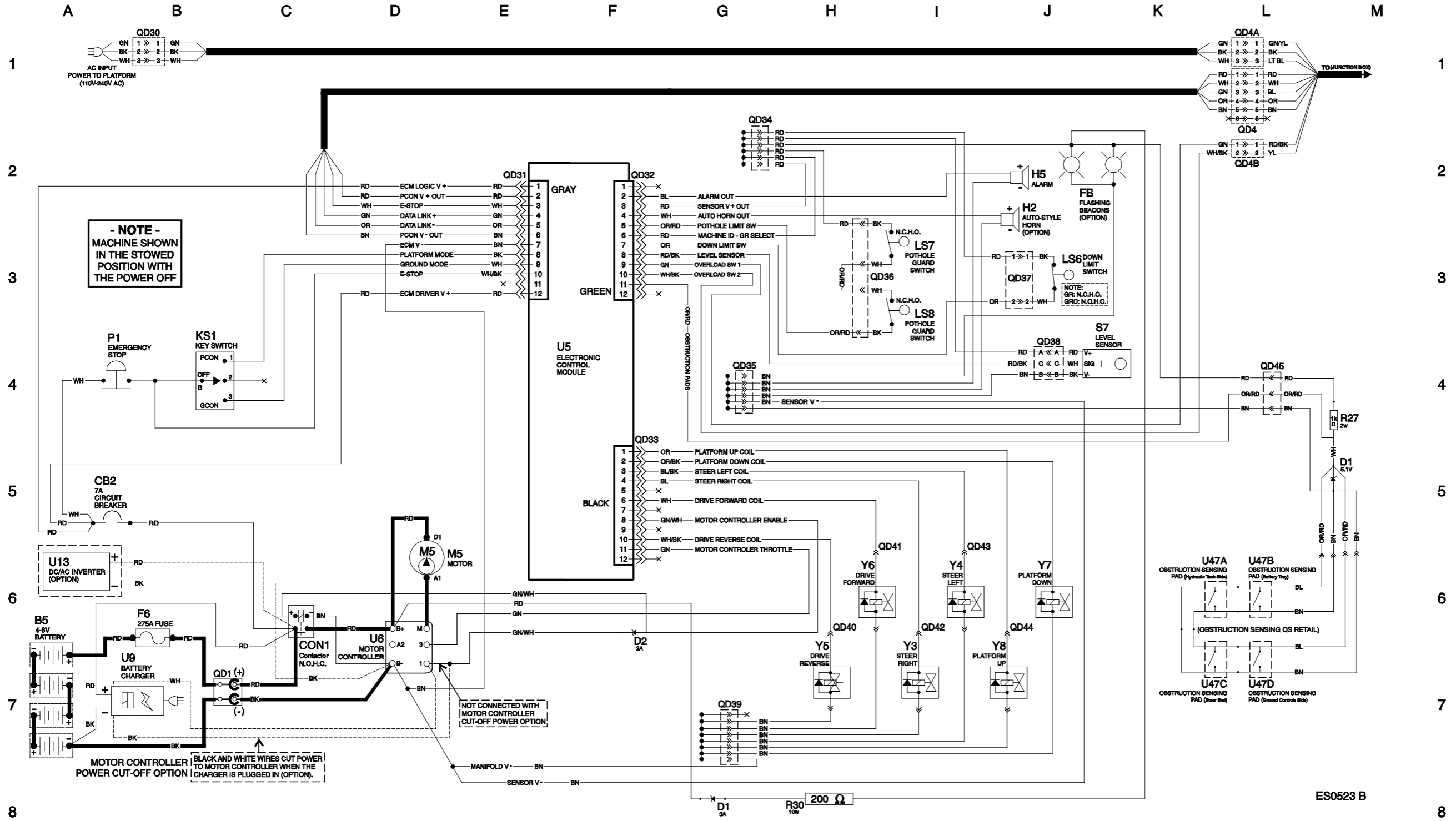

**Electrical Schematic, QSR, AS / CE**  
(from serial number QS11-1000 to QS11-1015)

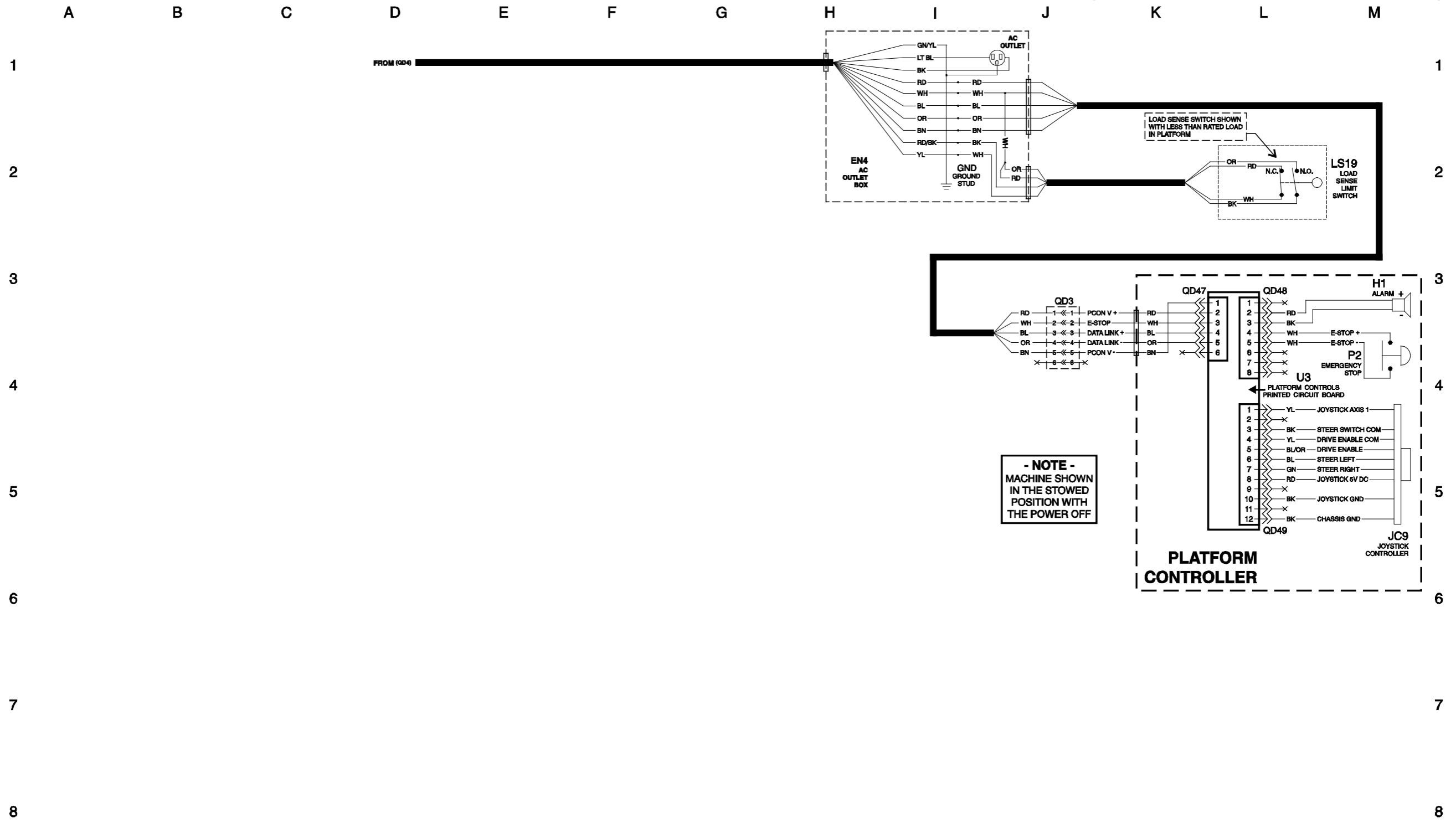

**Electrical Schematic, QSR, AS / CE**  
(from serial number QS11-1000 to QS11-1015)

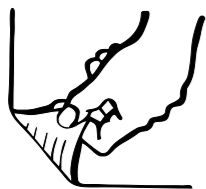

**Electrical Schematic, QSR, AS / CE**  
(from serial number QS11-1016 to QS14-1550)

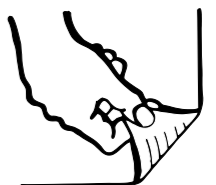





**Electrical Schematic, QSR, AS / CE**  
(from serial number QS11-1016 to QS14-1550)

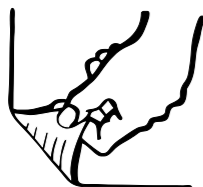

**Electrical Schematic, QSR, AS / CE**  
(from serial number QS14-1551 to QS15-2426)

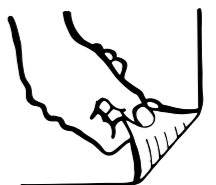

# Electrical Schematic, QSR, AS / CE (from serial number QS14-1551 to QS15-2426)

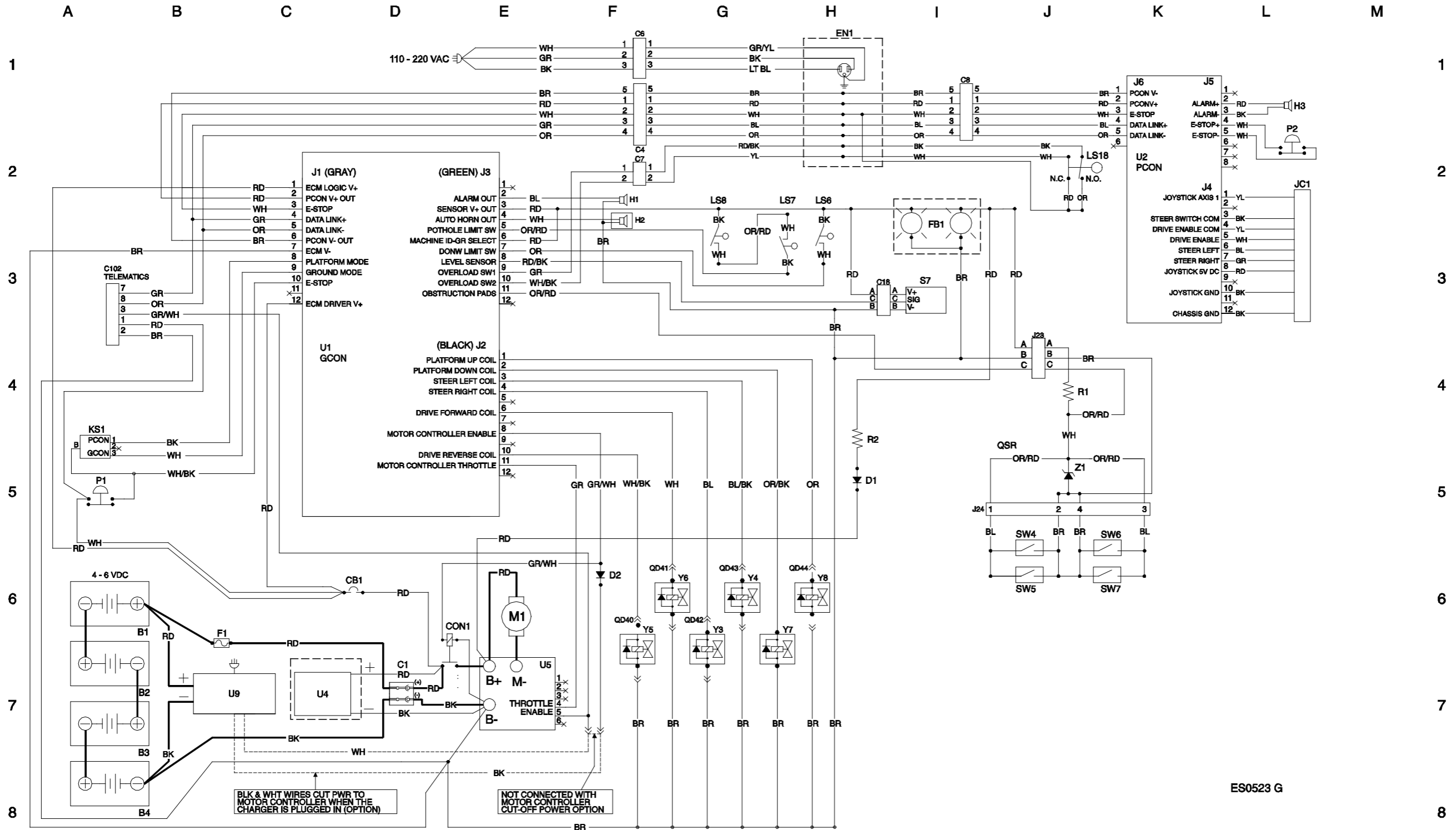

### Electrical Schematic, QSR, AS / CE (from serial number QS15-2427 to QS16P-2451)

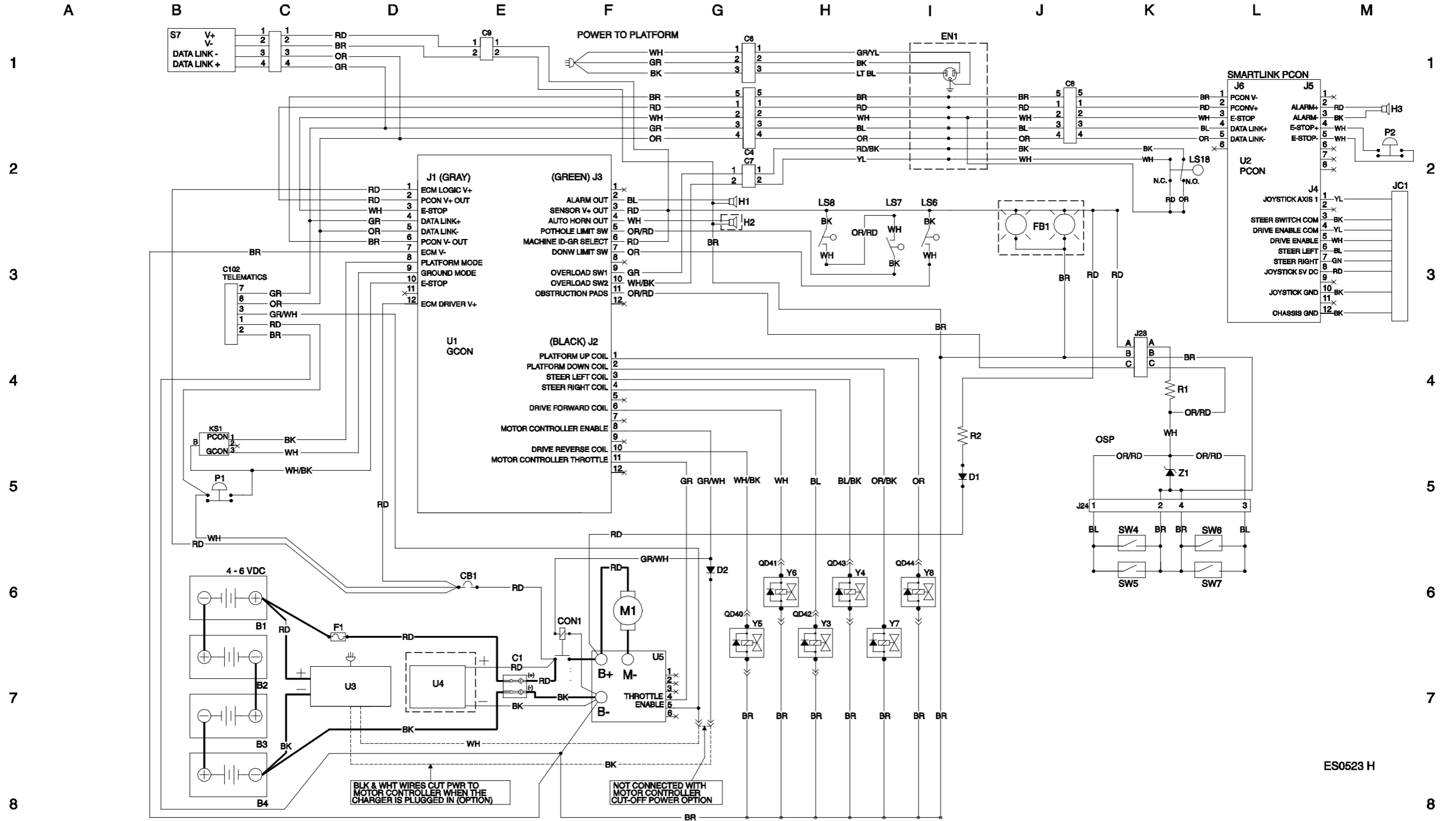

ES0523 H



**Electrical Schematic, QSR, AS / CE**  
(from serial number QS15-2427 to QS16P-2451)

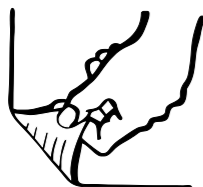

**Electrical Schematic, QSR, AS / CE**  
**(from serial number QS16P-2452 to QS16P-2468)**

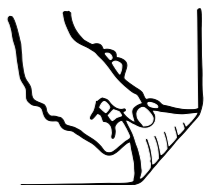

# Electrical Schematic, QSR, AS / CE (from serial number QS16P-2452 to QS16P-2468)

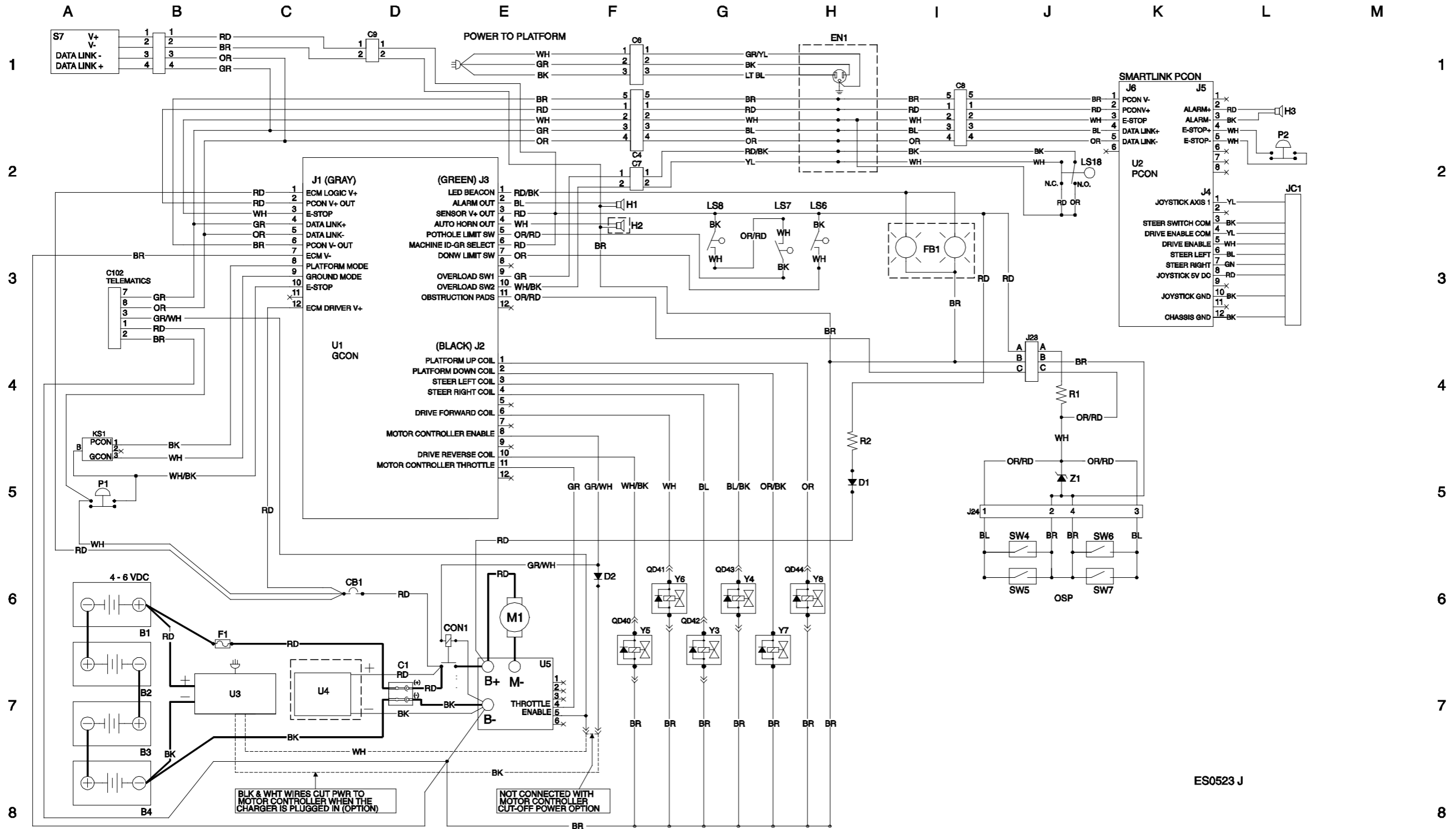

### Electrical Schematic, QSR, AS / CE (from serial number QS16P-2469 to QS16P-4499) (from serial number QSP-4500)

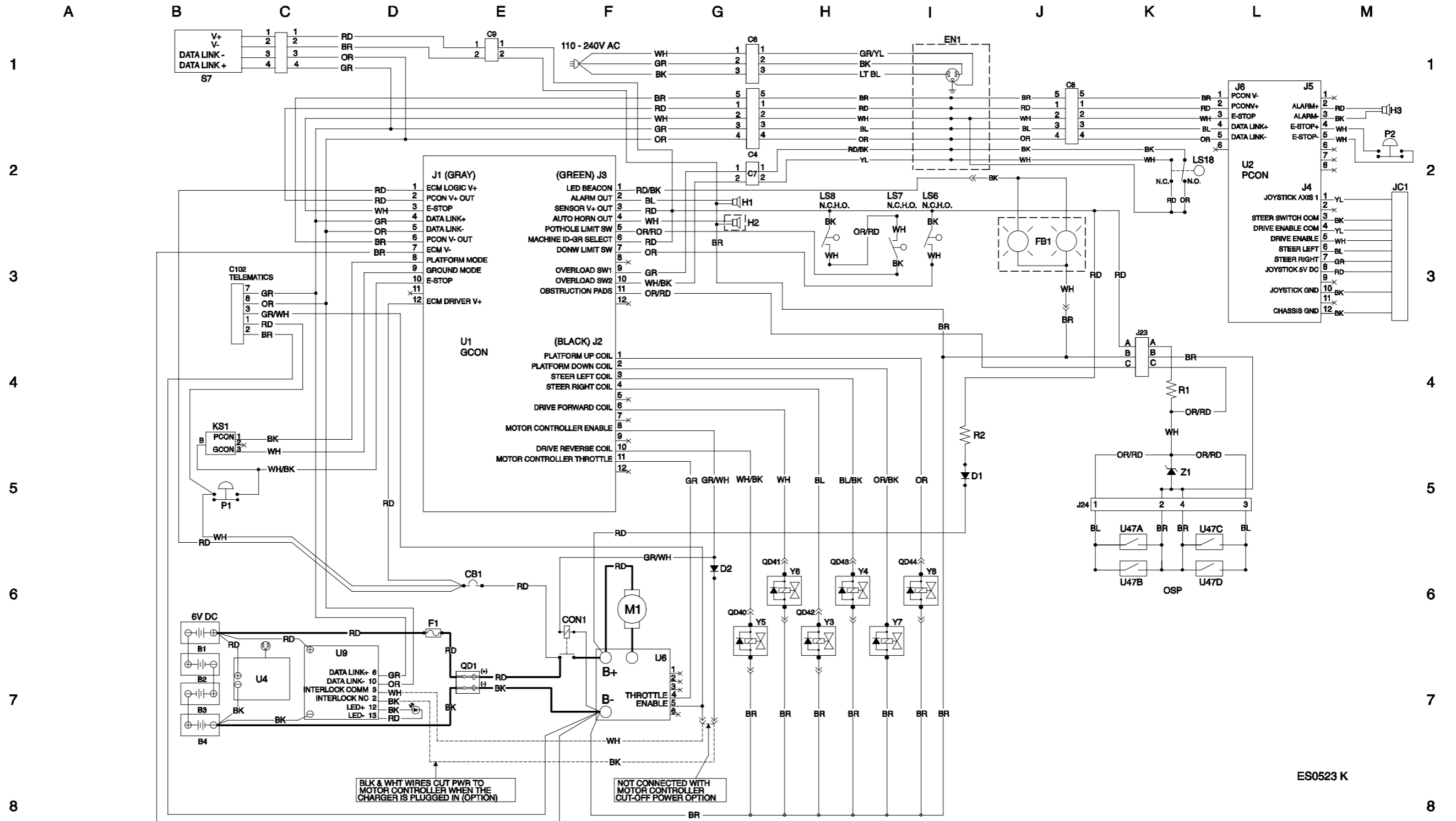

**Electrical Schematic, QSR, AS / CE**

(from serial number QS16P-2469 to QS16P-4499)

(from serial number QSP-4500)

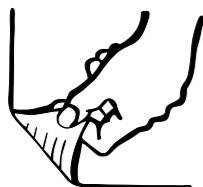

**Hydraulic Schematic, GR • QSR • QSW,  
(from serial numbers GR10-20000 to GR12-24138 and QS11-1000 to QS12-1063)**

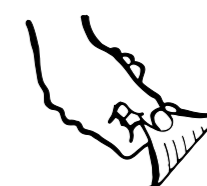

**Hydraulic Schematic, GR • QSR • QSW,**  
 (from serial numbers GR10-20000 to GR12-24138 and QS11-1000 to QS12-1063)

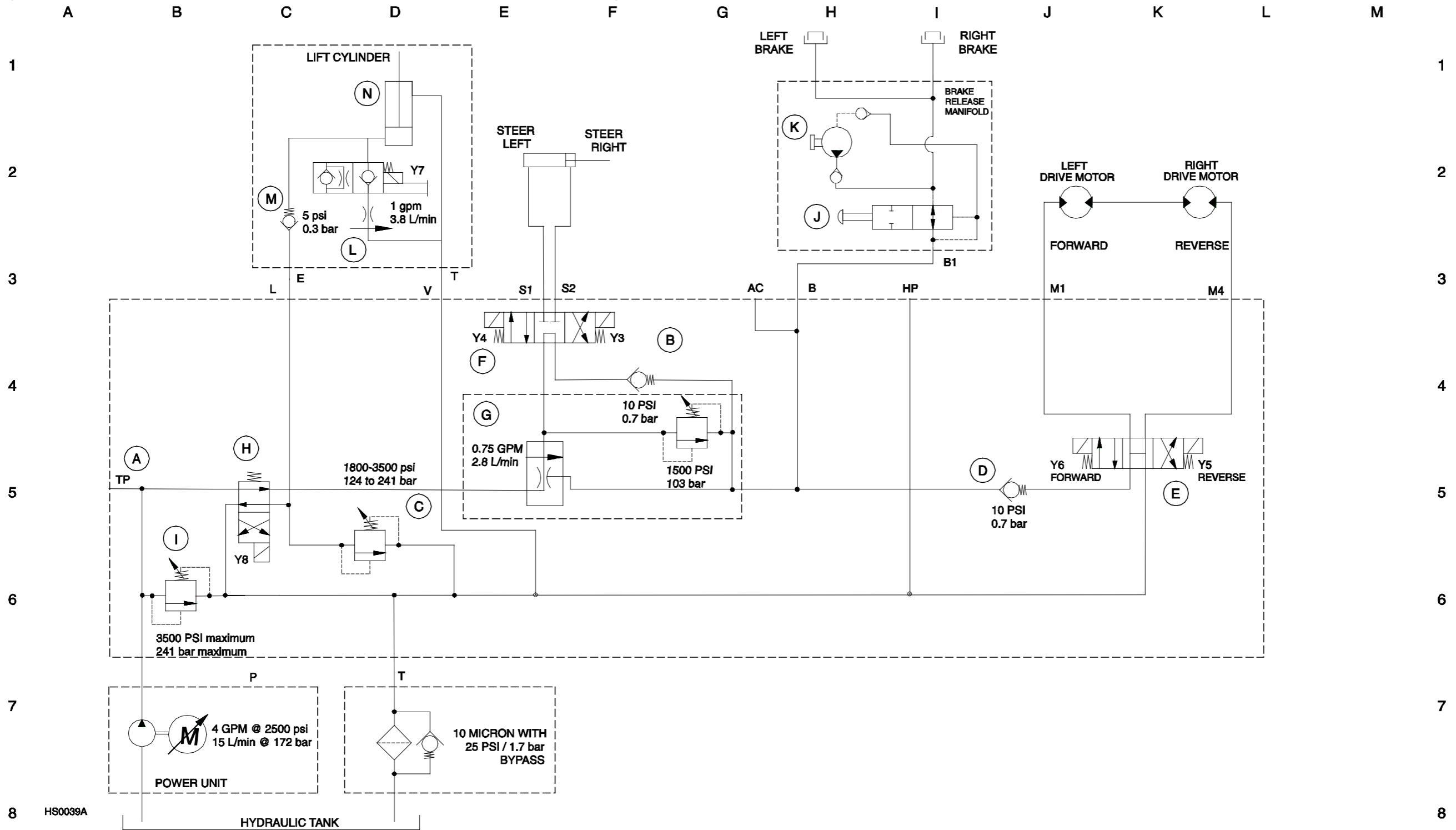

**Hydraulic Schematic, GR • QSR • QSW,**  
 (from serial numbers GR12-24139 to QS16P-46499 and QS12-1064 to QS16P-4499)  
 (from serial numbers GRP-46500 and QSP-4500)

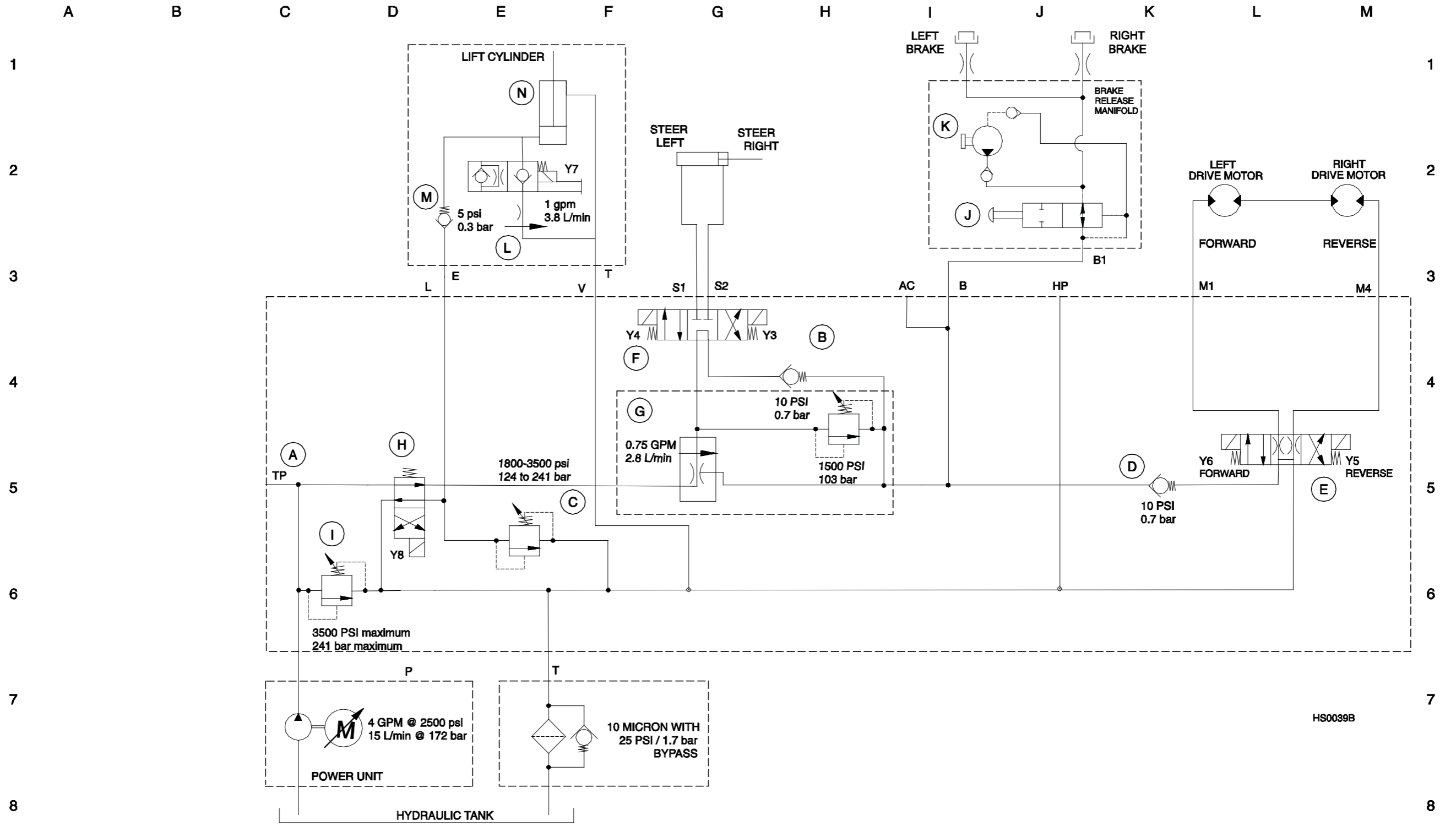

HS0039B

**Hydraulic Schematic, GR • QSR • QSW,**

**(from serial numbers GR12-24139 to GR16P-46499 and QS12-1064 to QS16P-4499)**

**(from serial numbers GRP-46500 and QSP-4500)**

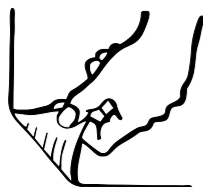

California Proposition 65



Operating, servicing and maintaining this equipment can expose you to chemicals including engine exhaust, carbon monoxide, phthalates, and lead, which are known to the State of California to cause cancer and birth defects or other reproductive harm. These chemicals can be emitted from or contained in other various parts and systems, fluids and some component wear by-products. To minimize exposure, avoid breathing exhaust, do not idle the engine except as necessary, service your equipment and vehicle in a well-ventilated area and wear gloves or wash your hands frequently when servicing your equipment or vehicle and after operation. For more information go to [www.P65Warnings.ca.gov/passenger-vehicle](http://www.P65Warnings.ca.gov/passenger-vehicle).